

The Rank One Abelian Stark Conjecture

Samit Dasgupta
Matthew Greenberg

March 11, 2011

To Smriti and Kristina

Contents

- 1 Statement of the conjecture** **7**

 - 1.1 A cyclotomic example 7
 - 1.2 The conjecture 8
 - 1.3 Further motivation— L -functions 10
 - 1.4 Trichotomy of the conjecture 13
 - 1.5 The Brumer–Stark–Tate conjecture 14
 - 1.6 Units, Shintani’s method, and group cohomology 17

- 2 Gross’s conjectures** **19**

 - 2.1 Gross’s tower of fields conjecture 19
 - 2.2 Signs in case TR_∞ 19
 - 2.3 Gross’s conjecture in case TR_p 20
 - 2.4 Gross’s “weak” conjecture in case TR_p 21

- 3 Shintani’s method** **23**

 - 3.1 Hurwitz zeta functions 23
 - 3.2 The Hurwitz zeta functions at nonpositive integers 26
 - 3.2.1 The multiple Γ -function 27
 - 3.3 Shintani zeta functions 27
 - 3.4 Special values of Shintani zeta functions 31
 - 3.4.1 Generalized Bernoulli polynomials 32
 - 3.4.2 An algebraic version of Shintani’s formula 32
 - 3.5 Derivatives of Shintani zeta functions at $s = 0$ 34
 - 3.5.1 The multiple sine function 35
 - 3.6 Partial zeta functions 36
 - 3.7 Shintani decompositions of partial zeta functions 38
 - 3.7.1 Dependence on rotation matrices 38
 - 3.7.2 Dependence on the cover 39
 - 3.7.3 Dependence on representative ideal 41
 - 3.8 Kronecker’s limit formula and Shintani zeta functions 41
 - 3.9 Complex cubic fields—the work of Ren and Sczech 44
 - 3.10 TR_∞ – The invariants of Shintani and Yamamoto 46

4 Eisenstein cocycles and applications to case TR_p	49
4.1 Motivation: Siegel's formula	49
4.1.1 Eisenstein series	49
4.1.2 The Dedekind-Rademacher homomorphism	52
4.1.3 Siegel's formula	53
4.1.4 The Eisenstein cocycle	56
4.1.5 Pairing between cohomology and homology	57
4.1.6 Smoothing	58
4.2 Sczech's construction of the Eisenstein cocycle	60
4.2.1 Sczech's definition of Ψ	61
4.2.2 A finite formula for Ψ	63
4.2.3 Proof of Theorem 4.7	67
4.2.4 The cocycle properties	70
4.2.5 Relationship with zeta functions	71
4.3 Integrality of the ℓ -smoothed cocycle Ψ_ℓ	73
4.3.1 A decomposition of the ℓ -smoothed Dedekind sum	74
4.3.2 The case $d = 0$	75
4.3.3 Proof of Theorem 4.15	76
4.4 Applications to Stark's conjecture	80
4.4.1 A cocycle of measures	80
4.4.2 p -adic zeta functions	82
4.4.3 A conjectural formula for Stark units	84
4.5 General degree	87
4.5.1 Sczech's construction of Ψ	88
4.5.2 ℓ -smoothing	89

Chapter 1

Statement of the conjecture

We begin with an example to motivate the rank one abelian Stark conjecture.

1.1 A cyclotomic example

Let f be a positive integer, and let a be an integer relatively prime to f . Define the partial zeta function

$$\zeta_f(a, s) = \sum_{\substack{n=1 \\ n \equiv a \pmod{f}}}^{\infty} \frac{1}{n^s}, \quad s \in \mathbf{C}, \operatorname{Re}(s) > 1.$$

Here the sum ranges over positive integers n congruent to a modulo f . If a is chosen in the range $0 < a \leq f$, then $\zeta_f(a, s)$ is related to the Hurwitz zeta function

$$\zeta_H(x, s) := \sum_{n=0}^{\infty} \frac{1}{(x+n)^s}, \quad x, s, \in \mathbf{C}, \operatorname{Re}(x) > 0, \operatorname{Re}(s) > 1,$$

by the relation

$$\zeta_f(a, s) = f^{-s} \zeta_H\left(\frac{a}{f}, s\right).$$

The function $\zeta_f(a, s)$ has a meromorphic continuation to \mathbf{C} , with a simple pole at $s = 1$ and no other poles. Since $\zeta_H(x, s)$ has a simple pole with residue 1 at $s = 1$, the Taylor expansion of $\zeta_f(a, s)$ at $s = 1$ begins

$$\zeta_f(a, s) = \frac{1}{f} \cdot \frac{1}{s-1} + b(a, f) + \cdots.$$

Stark's conjecture in this setting concerns the constants $b(a, f)$. However, the statement and generalization of the conjecture is cleaner if we change the point of interest from $s = 1$ to $s = 0$. These two points are related by the functional equation for the $\zeta_f(a, s)$, and hence contain the same "information." The constants $b(a, f)$ appear (after a simple transformation) as the leading terms of the Taylor expansions of $\zeta_f(a, s)$ at $s = 0$, and it is these leading terms that we will study.

We assume that $f \neq 1$, and we consider the symmetrized zeta functions

$$\zeta_f^+(a, s) = \zeta_f(a, s) + \zeta_f(-a, s).$$

As we discuss in greater generality below, this symmetrization ensures that $\zeta_f^+(a, 0) = 0$; indeed, for $0 < a < f$ we have $\zeta_f(a, s) = \frac{1}{2} - \frac{a}{f}$. Using the classical formula

$$\frac{d}{ds} \zeta_H(x, s)|_{s=0} = \log \Gamma(x) - \frac{1}{2} \log(2\pi)$$

for the derivative of the Hurwitz zeta function at $s = 0$, one finds that the Taylor expansion of $\zeta_f^+(a, s)$ at $s = 0$ begins:

$$\zeta_f^+(a, s) = c(a, f)s + \dots,$$

where

$$\begin{aligned} c(a, f) &= \log \frac{\Gamma(\frac{a}{f})\Gamma(1 - \frac{a}{f})}{2\pi} \\ &= -\log \left(2 \sin \left(\frac{\pi a}{f} \right) \right) \\ &= -\frac{1}{2} \log \left(2 - 2 \cos \left(\frac{2\pi a}{f} \right) \right). \end{aligned}$$

We may write

$$c(a, f) = -\frac{1}{2} \log(u(a, f)) \quad \text{where} \quad u(a, f) = (1 - \zeta_f^a)(1 - \zeta_f^{-a}). \quad (1.1)$$

Here $\zeta_f := e^{2\pi i/f}$, and $u(a, f)$ is an f -unit in the totally real cyclotomic field

$$\mathbf{Q}(\zeta_f)^+ = \mathbf{Q}(\zeta_f + \zeta_f^{-1}) \subset \mathbf{Q}(\zeta_f).$$

Furthermore, if f is divisible by at least two distinct primes, then $u(a, f)$ is actually a unit, not just an f -unit.

In summary, we have shown that the partial zeta function $\zeta_f^+(a, s)$ has a zero at $s = 0$, and that its derivative at $s = 0$ is the constant $-1/2$ times the logarithm of an f -unit. Stark's rank one abelian conjecture is a generalization of this statement to abelian extensions of number fields K/F , in place of $\mathbf{Q}(\zeta_f)^+/\mathbf{Q}$ in this example. The reason that we considered the symmetrized zeta function $\zeta_f^+(a, s)$ rather than $\zeta_f(a, s)$ (and correspondingly the extension $\mathbf{Q}(\zeta_f)^+$ rather than $\mathbf{Q}(\zeta_f)$) is that the real place of \mathbf{Q} splits completely in $\mathbf{Q}(\zeta_f)^+$, but not in $\mathbf{Q}(\zeta_f)$. Stark's conjecture, as formulated by Tate, considers more generally any place of F that splits completely in K —real, complex, or finite.

1.2 The conjecture

Let K/F denote an abelian extension of number fields with associated rings of integers $\mathcal{O}_K, \mathcal{O}_F$. Let S denote a finite set of places of F containing the archimedean places and

those which ramify in K . Assume that S contains at least one place v that splits completely in K and that $|S| \geq 2$. For each ideal $\mathfrak{n} \subset \mathcal{O}_F$ not divisible by a prime that ramifies in K , we denote by $\sigma_{\mathfrak{n}}$ the associated Frobenius element in $G := \text{Gal}(K/F)$. For each element $\sigma \in G$, we define the partial zeta function

$$\zeta_{K/F,S}(\sigma, s) := \sum_{\substack{\mathfrak{n} \subset \mathcal{O}_F \\ (\mathfrak{n}, S) = 1, \sigma_{\mathfrak{n}} = \sigma}} \frac{1}{\text{Nn}^s}, \quad s \in \mathbf{C}, \text{Re}(s) > 1. \quad (1.2)$$

Here Nn denotes the norm of the ideal \mathfrak{n} . In the example of Section 1.1, we have $F = \mathbf{Q}$, $K = \mathbf{Q}(\zeta_f)^+$, $S = \{\infty, p \mid f\}$, and $\zeta_f(a, s) = \zeta_{K/F,S}(\sigma_a, s)$. Each function $\zeta_{K/F}(\sigma, s)$ has a meromorphic continuation to \mathbf{C} , with a simple pole at $s = 1$ and no other poles. As explained in the Section 1.3, the fact that S contains a place v that splits completely in K ensures that $\zeta_{K/F,S}(\sigma, 0) = 0$ for all $\sigma \in G$. Denote by e the number of roots of unity in K . Let $U_{v,S} = U_{v,S}(K)$ denote the set of elements $u \in K^\times$ such that:

- if $|S| \geq 3$, then $|u|_{w'} = 1$ for all $w' \nmid v$;
- if $S = \{v, v'\}$, then $|u|_{w'}$ is constant over all w' above v' , and $|u|_{w'} = 1$ for all $w' \notin S$.

The following is the rank one abelian Stark conjecture.

Conjecture 1.1 (Stark). *Fix a place w of K lying above v . There exists a $u \in U_{v,S}$ such that*

$$\zeta'_{K/F,S}(\sigma, 0) = -\frac{1}{e} \log |u^\sigma|_w \text{ for all } \sigma \in G \quad (1.3)$$

and such that $K(u^{1/e})/F$ is an abelian extension.

In the example of Section 1.1, we had

$$u = u(1, f) = (1 - \zeta_f)(1 - \zeta_f^{-1}) = 2 - 2 \cos\left(\frac{2\pi}{f}\right),$$

$$u^{\sigma_a} = u(a, f).$$

We checked equation (1.3) and the condition $u \in U_{v,S}$ in the case when f is divisible by at least 2 primes (i.e. when $|S| \geq 3$). Exercise: in this example, check that $u \in U_{v,S}$ in the case $|S| = 2$, and that the condition that $K(u^{1/e})/F$ is abelian holds.

Returning to the general case, note that the conditions $u \in U_{v,S}$ and equation (1.3) together specify the absolute value of u at every place of K . Therefore, if the unit u exists, it is unique up to multiplication by a root of unity in K^\times . In order to state an alternate equivalent version of Conjecture 1.1 in which the relevant unit is actually unique (not just up to a root of unity), we introduce a finite set T of primes of F such that $S \cap T = \varnothing$. We define “smoothed” zeta functions $\zeta_{K/F,S,T}(\sigma, s)$ by the group ring equation

$$\sum_{\sigma \in G} \zeta_{K/F,S,T}(\sigma, s) [\sigma^{-1}] = \prod_{\mathfrak{c} \in T} (1 - [\sigma_{\mathfrak{c}}^{-1}] \text{Nc}^{1-s}) \sum_{\sigma \in G} \zeta_{K/F,S}(\sigma, s) [\sigma^{-1}] \quad (1.4)$$

in $\mathbf{C}[G]$. For example, if T is a one-element set $\{\mathfrak{c}\}$, then

$$\zeta_{K/F,S,T}(\sigma, s) = \zeta_{K/F,S}(\sigma, s) - N\mathfrak{c}^{1-s} \zeta_{K/F,S}(\sigma\sigma_{\mathfrak{c}}^{-1}, s).$$

Let $U_{v,S,T}$ denote the finite index group of $U_{v,S}$ consisting of the $u \in U_{v,S}$ such that $u \equiv 1 \pmod{\mathfrak{c}\mathcal{O}_K}$ for every prime $\mathfrak{c} \in T$. We assume that there are no non-trivial roots of unity in $U_{v,S,T}$. This condition is automatically satisfied if either T contains two distinct primes with different residue characteristics, or one prime with residue characteristic at least 2 plus its absolute ramification index.

Stark's rank one abelian conjecture has the following equivalent formulation. It was stated by Tate in this form in [33].

Conjecture 1.2 (Stark–Tate). *Fix a place w of K lying above v . There exists an element $u_T \in U_{v,S,T}$ such that*

$$\zeta'_{K/F,S,T}(\sigma, 0) = -\log |u_T^\sigma|_w \text{ for all } \sigma \in G. \quad (1.5)$$

Note that u_T , if it exists, is uniquely determined by the conditions of Conjecture 1.2 since we have assumed that $U_{v,S,T}$ contains no non-trivial roots of unity. Exercise: check the equivalence of Conjectures 1.1 and 1.2 (see [33]); the elements u and u_T of the two conjectures are related by the equation $u_T = (u^{1/e})^{g_T}$, where $g_T = \prod_{\mathfrak{c} \in T} (1 - [\sigma_{\mathfrak{c}}^{-1}] N\mathfrak{c}) \in \mathbf{Z}[G]$. Note that g_T annihilates roots of unity.

1.3 Further motivation— L -functions

Conjecture 1.1 can be motivated by viewing it as a generalization of the Dirichlet class number formula. For a finite set of places S of F containing the infinite places, the S -imprimitive Dedekind zeta function of F is the special case of the function $\zeta_{K/F,S}$ defined in (1.2) for $K = F$, namely,

$$\zeta_{F,S}(s) := \sum_{\substack{\mathfrak{n} \subset \mathcal{O}_F \\ (\mathfrak{n}, S) = 1}} \frac{1}{N\mathfrak{n}^s} = \prod_{\mathfrak{p} \notin S} (1 - N\mathfrak{p}^{-s})^{-1}, \quad \operatorname{Re}(s) > 1. \quad (1.6)$$

Here \mathfrak{p} ranges over the set of primes of F not contained in S . The function $\zeta_{F,S}$ can be extended to a meromorphic function on the complex plane that satisfies a functional equation relating the values at s and $1-s$. The function $\zeta_{F,S}$ has a simple pole at $s = 1$; the Dirichlet class number formula gives the residue at this pole. Using the functional equation, the Dirichlet class number formula has the following elegant formulation at $s = 0$:

Theorem 1.3. *The Taylor series of $\zeta_{F,S}(s)$ at $s = 0$ begins:*

$$\zeta_{F,S}(s) = -\frac{h_S R_S}{e_F} s^{|S|-1} + O(s^{|S|}), \quad (1.7)$$

where h_S and R_S are the S -class number and S -regulator of F defined below, and e_F is the number of roots of unity in F .

Note that the order of vanishing of $\zeta_{F,S}(s)$ at $s = 0$ is the rank

$$r_S = |S| - 1 \quad (1.8)$$

of the group of S -units $\mathcal{O}_{F,S}^\times$, as given by the Dirichlet unit theorem. The S -class number of F is defined as $h_S = |\text{Cl}(\mathcal{O}_{F,S})|$, the class number of the ring of S -integers of F . The group $\text{Cl}(\mathcal{O}_{F,S})$ may be identified with the quotient of the usual class group $\text{Cl}(\mathcal{O}_F)$ by the subgroup generated by the images of the finite primes in S . The S -regulator of F is defined as follows. Let u_1, \dots, u_{r_S} be a basis for the quotient of $\mathcal{O}_{F,S}^\times$ by its torsion subgroup. Denote the elements of S by v_0, v_1, \dots, v_{r_S} . Then the S -regulator of F is the absolute value of the determinant of a certain $(r_S \times r_S)$ -matrix:

$$R_S = \left| \det(\log(|u_i|_{v_j}))_{1 \leq i, j \leq r_S} \right|.$$

Notice that the place v_0 has been ignored in the definition of R_S . One checks that the definition of R_S is independent of the various choices made.

Now let us turn to our setting of interest, namely a finite abelian extension K/F of number fields. For each character $\chi: G \rightarrow \mathbf{C}^\times$ we define an associated L -function by the formula

$$L_S(\chi, s) = \sum_{\sigma \in G} \chi(\sigma) \zeta_{K/F,S}(\sigma, s) = \sum_{\substack{\mathfrak{n} \subset \mathcal{O}_F \\ (n, S) = 1}} \frac{\chi(\sigma)}{N\mathfrak{n}^s}, \quad (1.9)$$

where the second formula holds for $\text{Re}(s) > 1$. In certain respects, the L -functions of characters are better behaved than the partial zeta functions $\zeta_{K/F,S}(\sigma, s)$. For instance, they possess Euler products:

$$L_S(\chi, s) = \prod_{\mathfrak{p} \notin S} (1 - \chi(\mathfrak{p}) N\mathfrak{p}^{-s})^{-1}. \quad (1.10)$$

Furthermore, there is a functional equation relating $L_S(\chi, s)$ and $L_S(\bar{\chi}, 1 - s)$. Also, there is an explicit formula for the order of vanishing of $L_S(\chi, s)$ at $s = 0$:

$$\begin{aligned} r_S(\chi) &= \dim_{\mathbf{C}}(\mathcal{O}_{S_K}^\times \otimes \mathbf{C})^{\chi^{-1}} \\ &= \begin{cases} |\{v \in S : \chi(G_v) = 1\}| & \text{if } \chi \neq 1 \\ |S| - 1 & \text{if } \chi = 1, \end{cases} \end{aligned} \quad (1.11)$$

where S_K denotes the set of places of K above the places in S , $G_v \subset G$ denotes the decomposition group at v , and the superscript χ^{-1} denotes the “ χ^{-1} -component”:

$$(\mathcal{O}_{S_K}^\times \otimes \mathbf{C})^{\chi^{-1}} := \{x \in \mathcal{O}_{S_K}^\times \otimes \mathbf{C} : \sigma(x) = \chi^{-1}(\sigma)x \text{ for all } \sigma \in G\}.$$

The zeta function $\zeta_{K,S_K}(s)$ can be factored in terms of the L -functions associated to the abelian extension K/F :

$$\zeta_{K,S_K}(s) = \prod_{\chi \in \hat{G}} L_S(\chi, s). \quad (1.12)$$

Note that the factor on the right corresponding to $\chi = 1$ is $L_S(1, s) = \zeta_{F,S}(s)$. This factorization formula can be proven directly from the Euler products (1.6) and (1.10). (Exercise 1: Prove (1.12). Exercise 2: prove that (1.12) is consistent with the orders of vanishing at $s = 0$ of both sides given by (1.8) and (1.11), i.e. prove that

$$|S_K| - 1 = |S| - 1 + \sum_{\chi \neq 1} |\{v : \chi(G_v) = 1\}|.$$

Stark's motivation for his conjectures was the idea that in harmony with equation (1.12), the leading term $-h_{S_K} R_{S_K}/e_K$ of $\zeta_{K,S_K}(s)$ at $s = 0$ should factor in a nice way over the various characters χ . More precisely, the leading term of $L_S(\chi, s)$ at $s = 0$ should be expressible as a rational number times the determinant of an $r_S(\chi) \times r_S(\chi)$ -matrix whose entries are linear forms of logarithms of elements of $(\mathcal{O}_{S_K}^\times \otimes \mathbf{C})^{X^{-1}}$.

We do not deal with the general formulation of Stark's conjecture in this article. Instead, we concentrate on the "rank one" setting, which concerns only the first derivative of $L_S(\chi, s)$ at $s = 0$ in the case $r_S(\chi) \geq 1$ for all χ . The reason that in the statement of the rank one abelian Stark conjecture (Conjecture 1.1) we assume that $|S| \geq 2$ and that S contains a place that splits completely in K (i.e. such that $G_v = 1$) is that this implies that $r_S(\chi) \geq 1$ for all χ , by (1.11). Using equation (1.9), one easily checks that the following is an equivalent formulation of the conjecture.

Conjecture 1.4 (Stark). *Suppose that $v \in S$ splits completely in K , and fix a place $w \in S_K$ above v . There exists a $u \in U_{v,S}$ such that*

$$L'_S(\chi, 0) = -\frac{1}{e} \sum_{\sigma \in G} \chi(\sigma) \log |u^\sigma|_w \text{ for all } \chi \in \hat{G} \quad (1.13)$$

and such that $K(u^{1/e})/F$ is an abelian extension.

Note that the element

$$u^{X^{-1}} := \sum_{\sigma \in G} u^\sigma \otimes \chi(\sigma) \in \mathcal{O}_{K,S}^\times \otimes \mathbf{C}$$

lies in $(\mathcal{O}_{K,S}^\times \otimes \mathbf{C})^{X^{-1}}$, and that the sum in (1.13) is simply the value of the linear extension of $\log |\cdot|_w$ to $\mathcal{O}_{K,S}^\times \otimes \mathbf{C}$, evaluated at $u^{X^{-1}}$.

If $|S| \geq 3$ and S contains at least two places that split completely in S , then $r(\chi) \geq 2$ for all χ and Conjecture 1.4 holds trivially with $u = 1$. Exercise: prove that Conjecture 1.4 holds if $|S| = 2$ and both places of S split completely in K .

We conclude this section by noting that Stark's conjecture is known to be true in the cases where one has an explicit class theory. Namely, when $F = \mathbf{Q}$ and v is the infinite place, we essentially proved Conjecture 1.1 in Section 1.1 using the cyclotomic units $u(a, f)$ defined in (1.1). When $F = \mathbf{Q}$ and v is a finite prime p , Conjecture 1.1 follows from Stickelberger's Theorem (see the discussion in Section 1.6). When F is a quadratic imaginary field, Stark proved the conjecture himself using the theory of elliptic units and Kronecker's second limit

formula [32]. There are certain other special cases known. For example, if K/F is a quadratic extension, then one can prove Conjecture 1.4 since the leading term of $L_S(\chi, s)$ for the nontrivial character $\chi \in \hat{G}$ is determined by the factorization formula (1.12)

$$L_S(\chi, s) = \frac{\zeta_{K,S_K}(s)}{\zeta_{F,S}(s)}$$

together with the Dirichlet class number formula (1.7). Sands generalized this method to prove Conjecture 1.4 when the abelian group G has exponent 2 and the place v is finite (with some small exceptions) [21]. We do not attempt to give a complete list of the known cases of the conjecture here, but we remark that the only ground fields F for which the conjecture is known for all abelian extensions K/F are the ones mentioned already, namely $F = \mathbf{Q}$ and F a quadratic imaginary field. In this article, we consider Conjecture 1.4 in all cases for which it applies and is nontrivial.

1.4 Trichotomy of the conjecture

In view of the fact that the rank one abelian Stark conjecture holds trivially when S contains two primes that split completely in K , we need only consider the setting where S contains exactly one prime v that splits completely in K . Since complex places split completely in every extension, we are left with the following possibilities:

- Case TR_∞ : F is totally real, and the place v is real. The places of K above v are real, and all other archimedean places are complex.
- Case ATR : F is “almost totally real,” i.e. it has one complex place v and all other places are real. The field K is totally complex.
- Case TR_p : F is totally real and the place v is finite. The field K is totally complex.

In case TR_∞ , equation (1.3) gives an exact formula for u and its conjugates up to sign:

$$u^\sigma = \pm \exp(-2\zeta'_{K/F,S}(\sigma, 0)) \text{ in the real embedding } w. \quad (1.14)$$

Exercise: As mentioned before, the Stark unit u is only unique up to sign. Prove, however, that the condition that $K(u^{1/2})/F$ is abelian implies that the sign of u^σ in the real embedding w is the same for all σ . Therefore, we may make the convention that the sign in (1.14) is $+$ for all σ .

Equation (1.14) has striking implications for explicit class field theory for the extension K/F . In computational terms, it is possible to write down the characteristic polynomial of u_T over F in the real embedding v by taking as coefficients the appropriate elementary symmetric functions of the values in (1.14). Then, assuming that a basis for \mathcal{O}_F is known, it is possible to “recognize” these real numbers as elements of F using standard lattice algorithms (such as LLL) and thereby write down the characteristic polynomial of u as an element of $F[x]$. In this way, Stark’s conjecture in case TR_∞ can be viewed as giving progress

towards an explicit class field theory for F and has significance in the study of Hilbert’s 12th problem. Many computations of this form were carried out in [13].

Exponentiating (1.5) provides the following formula analogous to (1.14) for u_T and its conjugates:

$$u_T^\sigma = \pm \exp(-\zeta'_{K/F,S,T}(\sigma, 0)) \text{ in the real embedding } w. \quad (1.15)$$

The units u_T are unique (not just up to sign). In [16], Gross stated a general conjecture that in particular addresses the question of the \pm signs in (1.15). Gross’s conjectures will be the topic of the next chapter.

Let us now consider case ATR. Since the place w is complex, inverting equation (1.5) only yields a formula for the absolute value of u_T and its conjugates:

$$|u_T^\sigma|_w = \exp(-\zeta'_{K/F,S,T}(\sigma, 0)).$$

This equation does not provide a formula for the image of $u_T \in \mathbf{C}$ under the embedding w itself. The distinction with case TR_∞ is that the group of elements of \mathbf{C}^\times with absolute value 1 is an entire circle, not merely the finite set $\{\pm 1\}$. Unless we can somehow specify the *argument* of the complex number u_T , it is not possible to directly write down the characteristic polynomial of u_T as an element of $F[x]$ as simply as we suggested in case TR_∞ .¹ Therefore, in case ATR, Stark’s conjecture does not directly make contact with explicit class field theory and Hilbert’s 12th problem. This leads us to the central motivating question addressed by this article.

Question 1.5. *Can we give, in all three cases of the rank one abelian Stark conjecture, an exact formula for the image of u_T at the place w rather than just a formula for its absolute value?*

As we will see, the answer to this question is “yes,” though the formulas that arise are not stated as succinctly as Stark’s conjecture. Since equation (1.14) together with Gross’s Conjecture 2.1 essentially answers this question in case TR_∞ , we concentrate on the two other cases in this article. (There are, however, several interesting papers featuring alternate conjectural constructions of Stark’s units in case TR_∞ , including [27], [1], and [35].)

In the ATR case, there are two techniques for deriving formulas for $u_T \in \mathbf{C}$. Ren and Sczech [20] construct candidates for Stark units using Shintani’s method, especially his decomposition of the quantity $\zeta'_{K/F,S}(\sigma, 0)$ in the case where K/F is complex cubic. Another approach, based on periods of Eisenstein series, was developed by Charollois and Darmon [4]. This theory is applicable in the case where the ATR field F admits a totally real subfield F^+ with $[F : F^+] = 2$. Extending these constructions to arbitrary ATR fields and unifying them is an interesting open problem.

1.5 The Brumer–Stark–Tate conjecture

Let us unwind Conjecture 1.2 in case TR_p , where F is a totally real field and v is a finite prime $\mathfrak{p} \subset \mathcal{O}_F$. In this case, we may define $R = S - \{\mathfrak{p}\}$ and consider the partial zeta

¹See, however, the computations of Stark units carried out for cubic ATR fields in [14].

function $\zeta_{K/F,R,T}(\sigma, s)$. Since \mathfrak{p} splits completely in K , we have

$$\zeta_{K/F,S,T}(\sigma, s) = (1 - N\mathfrak{p}^{-s})\zeta_{K/F,R,T}(\sigma, s).$$

Differentiating and evaluating at $s = 0$, we obtain the following expression for the left side of (1.5):

$$\zeta'_{K/F,S,T}(\sigma, 0) = (\log N\mathfrak{p}) \cdot \zeta_{K/F,R,T}(\sigma, 0).$$

Meanwhile, for the right side of (1.5), we fix a place $w = \mathfrak{P}$ above \mathfrak{p} and note that

$$-\log |u_T^\sigma|_{\mathfrak{P}} = (\log N\mathfrak{p}) \operatorname{ord}_{\mathfrak{P}}(u_T^\sigma),$$

where $\operatorname{ord}_{\mathfrak{P}} \in \mathbf{Z}$ is the usual \mathfrak{P} -adic valuation. Equation (1.5) can hence be written

$$\operatorname{ord}_{\mathfrak{P}}(u_T^\sigma) = \zeta_{K/F,R,T}(\sigma, 0). \quad (1.16)$$

This equation makes sense, because it is known that the right side of (1.16) is an integer. This integrality result is due independently to Deligne–Ribet [12], Cassou-Nogues [3], and Barsky [2]. We will give a proof in the case that F is a real quadratic field (and describe the proof of a partial result in the general totally real field case) in Chapter 4.

The left side of (1.16) can alternatively be written $\operatorname{ord}_{\mathfrak{P}^{\sigma^{-1}}}(u_T)$. Therefore if we let

$$\theta_{R,T} := \sum_{\sigma \in G} \zeta_{K/F,R,T}(\sigma, 0)[\sigma^{-1}] \in \mathbf{Z}[G],$$

then the element $u_T \in K^\times$ (which is a unit outside the places above \mathfrak{p}) is a generator of the ideal

$$\mathfrak{P}^{\theta_{R,T}} = \prod_{\sigma \in G} (\mathfrak{P}^{\sigma^{-1}})^{\zeta_{K/F,R,T}(\sigma, 0)}.$$

These steps are reversible—if $\mathfrak{P}^{\theta_{R,T}}$ is a principal ideal admitting a generator u_T satisfying $|u_T| = 1$ at all archimedean places of K and $u_T \equiv 1 \pmod{\mathfrak{c}\mathcal{O}_K}$ for all $\mathfrak{c} \in T$, then Conjecture 1.2 holds for the data $(K/F, S, T, \mathfrak{p})$.

Let us consider Conjecture 1.2 as the ideal \mathfrak{p} varies. Let $I_{K,T}$ denote the group of fractional ideals of K relatively prime to T . For any $\mathfrak{a} \in I_{K,T}$, consider the condition

$$\mathfrak{a}^{\theta_{R,T}} = (u) \quad (1.17)$$

for some $u \in K^\times$ such that $|u| = 1$ at every archimedean place of K and $u \equiv 1 \pmod{\mathfrak{c}}$ for all $\mathfrak{c} \in T$.² The set of \mathfrak{a} satisfying this condition is clearly a subgroup of $I_{K,T}$. It is easy to check that this subgroup contains the subgroup $P_{K,T} \subset I_{K,T}$ generated by principal ideals (α) where $\alpha \equiv 1 \pmod{\mathfrak{c}}$ for all $\mathfrak{c} \in T$. In particular, condition (1.17) depends only on the image of \mathfrak{a} in the generalized class group $A_{K,T} := I_{K,T}/P_{K,T}$. It is an easy exercise using the Chebotarev Density Theorem that the images of the primes \mathfrak{P} lying above primes $\mathfrak{p} \notin R \cup T$ that split completely in K generate the group $A_{K,T}$. Therefore, Conjecture 1.2 for the data $(K/F, R \cup \{\mathfrak{p}\}, T, \mathfrak{p})$ as \mathfrak{p} ranges over all primes not in $R \cup T$ that split completely in K is equivalent to the following statement.

²For $u \in K^\times$, $u \equiv 1 \pmod{\mathfrak{c}}$ means $\operatorname{ord}_{\mathfrak{q}}(u - 1) \geq \operatorname{ord}_{\mathfrak{q}}(\mathfrak{c})$ for all primes \mathfrak{q} of K dividing $\mathfrak{c}\mathcal{O}_K$.

Conjecture 1.6 (Brumer–Stark–Tate). *For all $\mathfrak{a} \in I_{K,T}$, we have $\mathfrak{a}^{\theta_{R,T}} = (u)$ for some $u \in K^\times$ such that $|u| = 1$ at every archimedean place of K and $u \equiv 1 \pmod{\mathfrak{c}}$ for all $\mathfrak{c} \in T$.*

This conjecture was actually formulated by Tate. However, the fact that $\theta_{R,T}$ annihilates the class group of K had been conjectured earlier by Brumer as a generalization of Stickelberger’s Theorem (which is a proof of this fact in the case $F = \mathbf{Q}$). Tate supplemented Brumer’s conjecture by adding the condition that not only should $\mathfrak{a}^{\theta_{R,T}}$ be principal for every ideal $\mathfrak{a} \subset \mathcal{O}_K$ relatively prime to R and T , but it should be generated by an element congruent to 1 $\pmod{\mathfrak{c}\mathcal{O}_K}$ for all $\mathfrak{c} \in T$ and with absolute value 1 at every archimedean place. This condition was inspired by (Tate’s formulation of) Stark’s Conjecture (Conjecture 1.2). For this reason, Tate called Conjecture 1.6 the Brumer–Stark conjecture; we have taken the liberty of adding Tate’s name above.

The formulation of Conjecture 1.6 shows that Stark’s conjecture in case TR_p is finite in the sense that it is true if we allow ourselves to multiply both sides of (1.5) by a sufficiently large positive integer. More precisely, the “rational” (as opposed to “integral”) version of Stark’s conjecture in case TR_p is true rather trivially:

Proposition 1.7. *Let F be a totally real field, and let \mathfrak{p} be a finite prime that splits completely in the totally complex finite abelian extension K . Let S and T be as above, with $\mathfrak{p} \in S$. There exists a unique $u_T \in U_{\mathfrak{p},S,T} \otimes \mathbf{Q}$ such that*

$$\zeta_{K/F,R,T}(\sigma, 0) = \mathrm{ord}_{\mathfrak{p}}(u_T^\sigma)$$

for all $\sigma \in G$.

Here the \mathfrak{P} -adic valuation $U_{\mathfrak{p},S,T} \rightarrow \mathbf{Z}$ has been linearly extended to $U_{\mathfrak{p},S,T} \otimes \mathbf{Q} \rightarrow \mathbf{Q}$.

Proof. Let h denote the size of $A_{K,T}$, and write $\mathfrak{P}^h = (\alpha)$. Then

$$u_T = \alpha^{\theta_{R,T}} \otimes \frac{1}{h}$$

is the desired element of $U_{\mathfrak{p},S,T} \otimes \mathbf{Q}$. □

Stark’s conjecture in case TR_p gives rather little information about the \mathfrak{p} -unit u_T ; namely, it describes the valuations of u_T at all the primes above \mathfrak{p} . In Chapter 2, we discuss two conjectures of Gross that refine Stark’s conjecture in case TR_p by providing more information about u_T . Gross’s “weak” conjecture describes the p -adic logarithm of the local norm of u_T from $K_{\mathfrak{P}}$ to \mathbf{Q}_p in terms of the derivative at zero of the p -adic partial zeta functions of F . Gross’s “strong” conjecture, which applies in case TR_∞ as well, is a strengthening that gives the image of u_T under the Artin reciprocity map of local class field theory.

We will provide an even stronger refinement of Stark’s conjecture in case TR_p in Chapter 4 by presenting an exact analytic formula for u_T in the completion $K_{\mathfrak{P}}$. This conjecture will answer our motivating question in case TR_p .

1.6 Units, Shintani's method, and group cohomology

The fields for which explicit theory class field theory is best understood are the rational field \mathbf{Q} and quadratic imaginary fields. Not coincidentally, these fields are distinguished by the fact that their unit groups are *finite*. In general, the special values of partial zeta functions of a number field F can often be expressed as *periods* parameterized by the unit group of F . We leave the term “period” in this context vague, but we have in mind an integral of a differential r -form along an r -cycle, where r is the rank of the unit group of F . As an example of such a formula, see Theorem 4.1 below. When $r = 0$, this “integral” degenerates to the value of a function—for example the function $e(x) := e^{2\pi ix}$ for $F = \mathbf{Q}$ and to elliptic functions for the case of F an imaginary quadratic field. Using CM theory, the values of these functions can be interpreted as invariants of algebraic objects and hence shown to be algebraic (and in fact, units living in the desired abelian extensions).

Units in the ground field F , therefore, play an important obstruction in our understanding of class field theory in general³ and Stark's conjectures in particular. In fact, the units in F will provide an obstacle to answering our motivating question, i.e. to providing exact formulas for Stark units. See (2.4) below for an explicit manifestation of this phenomenon in the case TR_p .

There are two broad principles that have appeared in the literature towards circumventing the obstruction provided by units in attempts to give exact formulas for Stark units. One method, inspired by Shintani's work, is to embed F into \mathbf{R}^n and to choose a fundamental domain for the action of the units of F that consists of a union of simplicial cones. One removes the ambiguity caused by units by considering only the elements of F lying in this fundamental domain; at the conclusion of any construction, one must prove that the construction is independent of the domain chosen. Shintani's method is the motivation for the works [27], [20], and [11], and is the topic of Chapter 3.

Another approach to deal with units in F is define a universal object—namely a certain “Eisenstein” cohomology class—that contains more information than the special values of the partial zeta functions of the number field F . To be (slightly) more precise, these classes will be in $H^r(\Gamma)$ for a group Γ equipped with homomorphism $\varphi_F : \mathcal{O}_F^\times \rightarrow G$. The class will have the property that special values of the partial zeta functions of F will appear as specializations of the class on the image of a basis of units under φ_F . Our conjectural formula for Stark units will occur as certain other specializations. One interesting feature is that our cohomology class will be universal in the sense that it does not depend on F , only its degree. The main point in this construction is that instead of considering an r -dimensional period of one function, we have lifted to an entire r -dimensional cohomology class. The cohomological method, with particular attention paid to the construction of Sczech [24] and its refinement in [5], is the topic of Chapter 4.

Solomon [30], [31], Hu [18], and Hill [17] have begin to unify these two approaches by defining certain cohomology classes using Shintani's method. The goal of the group project at

³Note, however, that there is a general CM theory that applies to CM number fields. This theory involves the study of abelian varieties and their endomorphisms. While much has been done in this direction, it is interesting to note that the (higher rank) Stark conjectures remain open for CM fields of degree greater than 2.

the Arizona Winter School will be to further develop this connection by finding relationships between the various different constructions of Eisenstein cohomology classes.

Chapter 2

Gross's conjectures

In 1988, Gross stated a conjectural refinement of Stark's Conjecture 1.2 [16]. In this chapter we state Gross's conjecture and study its implications in cases TR_∞ and TR_p .

2.1 Gross's tower of fields conjecture

Let the abelian extension K/F and finite sets of primes S and T of F be fixed as before, with the place $v \in S$ splitting completely in K . Assume that Conjecture 1.2 holds. Let L be a finite abelian extension of F containing K and unramified outside S . Since v splits completely in K and w is a place of K above v , there is a canonical isomorphism of completions: $F_v \cong K_w$. Let

$$\text{rec}_w : K_w \longrightarrow \mathbf{A}_K^\times \longrightarrow \text{Gal}(L/K) \quad (2.1)$$

denote the Artin reciprocity map of local class field theory. From the canonical inclusion $K^\times \subset K_w^\times$, we may evaluate rec_w on any element of K^\times . The following is [16, Conjecture 7.6].

Conjecture 2.1 (Gross, strong form). *Let $u_T \in U_{v,S,T} \subset K^\times$ denote Stark's unit satisfying Conjecture 1.2. Then*

$$\text{rec}_w(u_T^\sigma) = \prod_{\substack{\tau \in \text{Gal}(L/F) \\ \tau|_K = \sigma}} \tau^{-\zeta_{L/F,S,T}(\tau,0)} \quad (2.2)$$

in $\text{Gal}(L/K)$ for each $\sigma \in G$.

Note that the right side of (2.2) lies in $\text{Gal}(L/K)$ since

$$\sum_{\substack{\tau \in \text{Gal}(L/F) \\ \tau|_K = \sigma}} \zeta_{L/F,S,T}(\tau,0) = \zeta_{K/F,S,T}(\sigma,0) = 0.$$

2.2 Signs in case TR_∞

Let us consider Gross's Conjecture 2.1 in case TR_∞ . Here v and w are real places. Suppose that the places above v in the auxiliary extension L/F are complex; choose such a place

w' above w . Let $c \in \text{Gal}(L/K)$ denote the restriction to L of the complex conjugation on $L_{w'} \cong \mathbf{C}$. Then for $x \in K_w^\times \cong \mathbf{R}^\times$, we have

$$\text{rec}_w x = \begin{cases} 1 & \text{if } x > 0 \\ c & \text{if } x < 0. \end{cases}$$

Therefore, Gross's Conjecture 2.1 applied to this setting determines the signs of the unit u_T^σ in the real embedding w that were left ambiguous in (1.14). For example, if L is a quadratic extension of K , then the two elements $\tau, \tau' \in \text{Gal}(L/F)$ restricting to a given $\sigma \in G$ satisfy

$$\tau' \cdot \tau^{-1} = c, \quad \zeta_{L/F,S,T}(\tau', 0) = -\zeta_{L/F,S,T}(\tau, 0).$$

Therefore the right side of (2.2) simplifies to $c^{\zeta_{L/F,S,T}(\tau,0)}$, and we find that Conjecture 2.1 states:

$$u_T^\sigma > 0 \iff \zeta_{L/F,S,T}(\tau, 0) \text{ is even.}$$

More generally, if L/K is not necessarily quadratic, we choose representatives $\{\tau_i\}$ for

$$\{\tau \in \text{Gal}(L/F) : \tau|_K = \sigma\} / \{1, c\}$$

and find that Conjecture 2.1 states:

$$u_T^\sigma > 0 \iff \sum_{i=1}^{\lfloor [L:K]/2 \rfloor} \zeta_{L/F,S,T}(\tau_i, 0) \text{ is even.}$$

Exercise: Using class field theory, give necessary and sufficient conditions for the existence of an abelian L/F unramified outside S and with the places of L above v complex. In these cases Gross's Conjecture 2.1 can be used with the extension L (or more precisely its compositum with K) to determine the sign of u_T^σ .

2.3 Gross's conjecture in case TR_p

We now consider the implications of Gross's conjecture 2.1 in case TR_p . Let F be a totally real field, let v be a finite place \mathfrak{p} , and let K be totally complex finite abelian extension of F in which \mathfrak{p} splits completely. For concreteness, we assume that K is the maximal such extension with its given conductor \mathfrak{f} , that is, we assume that K is the maximal subfield of the narrow ray class field of F of conductor \mathfrak{f} in which \mathfrak{p} splits completely.

Next, we take the field $L = L_n$ in the statement of Gross's conjecture to be the narrow ray class field of conductor $\mathfrak{f}\mathfrak{p}^n$ for some positive integer n . The Artin reciprocity map (2.1) induces an isomorphism

$$\text{rec}_\mathfrak{p} : F_\mathfrak{p}^\times / E_\mathfrak{p}(\mathfrak{f})U_{\mathfrak{p},n} \cong \text{Gal}(L_n/K), \quad (2.3)$$

where $E_\mathfrak{p}(\mathfrak{f})$ denotes the group of totally positive \mathfrak{p} -units of F that are congruent to 1 modulo \mathfrak{f} , and $U_{\mathfrak{p},n} := 1 + \mathfrak{p}^n \mathcal{O}_{F,\mathfrak{p}}$ is the group of \mathfrak{p} -adic units congruent to 1 modulo \mathfrak{p}^n . Applying the inverse of the map $\text{rec}_\mathfrak{p}$ to equation (2.2), Conjecture 2.1 can be viewed as a formula for

the image of u_T^σ in $F_{\mathfrak{p}}^\times / E_{\mathfrak{p}}(\mathfrak{f})U_{\mathfrak{p},n}$, the left side of (2.3). (Here, u_T^σ is viewed as an element of $F_{\mathfrak{p}}^\times$ via $u_T^\sigma \in K \subset K_{\mathfrak{p}} \cong F_{\mathfrak{p}}$.) To make this precise, we fix an ideal $\mathfrak{a} \notin S \cup T$ of F whose associated Frobenius in $\mathrm{Gal}(K/F)$ is equal to σ . Conjecture 2.1 then states that the image of u_T^σ in $F_{\mathfrak{p}}^\times$ satisfies

$$u_T^\sigma \equiv \prod_{x \in F_{\mathfrak{p}}^\times / E_{\mathfrak{p}}(\mathfrak{f})U_{\mathfrak{p},n}} x^{-\zeta_{L_n/F, S, T}(\sigma_{\mathfrak{a} \cdot \mathrm{rec}_{\mathfrak{p}}(x)}, 0)} \pmod{E_{\mathfrak{p}}(\mathfrak{f})U_{\mathfrak{p},n}}. \quad (2.4)$$

Taking the limit as $n \rightarrow \infty$ gives a formula for the image of u_T^σ in $F_{\mathfrak{p}}^\times / \widehat{E_{\mathfrak{p}}(\mathfrak{f})}$, where the hat denotes topological closure. One of the goals of this article is to remove the ambiguity of $\widehat{E_{\mathfrak{p}}(\mathfrak{f})}$ inherent in Gross's conjecture by giving an exact conjectural formula for u_T^σ .

We should mention that we have not extracted the most information possible from Gross's conjecture in our analysis above, since the abelian extension L is allowed to have increased ramification at all primes above S . Furthermore, the valuation at \mathfrak{p} of the \mathfrak{p} -unit u_T^σ is specified by Conjecture 1.2, so we can reduce the ambiguity of $\widehat{E_{\mathfrak{p}}(\mathfrak{f})}$ to one provided by its subgroup $\widehat{E(\mathfrak{f})}$, where $E(\mathfrak{f})$ denotes the group of totally positive units of F congruent to 1 modulo \mathfrak{f} . These issues are discussed in [11, §3].

Furthermore, one can attempt to systematically increase knowledge about u_T^σ using Gross's conjecture by judiciously adding primes to the set S in the manner of Taylor and Wiles. This is discussed in [11, §5.4].

2.4 Gross's "weak" conjecture in case TR_p

Prior to stating Conjecture 2.1, Gross had stated another conjecture applicable in case TR_p [15]. This conjecture requires an additional assumption. Suppose that the finite place in S splitting completely in K , denoted \mathfrak{p} , has characteristic p ; we assume that S contains all the primes of F above p .

Let \mathcal{W} denote the *weight space* of continuous group homomorphisms $f : \mathbf{Z}_p^\times \rightarrow \mathbf{Z}_p^\times$.¹ The integers can be embedded as a dense subset of \mathcal{W} by associating to $k \in \mathbf{Z}$ the homomorphism $x \mapsto x^k$. For this reason, we write x^s instead of $s(x)$ for any $s \in \mathcal{W}$. Note also that \mathcal{W} is naturally an abelian group.

There exists, by independent work of Deligne–Ribet [12], Cassou-Nogues [3], and Barsky [2], for each $\sigma \in G$ a p -adic meromorphic function

$$\zeta_{K/F, S, p}(\sigma, s) : \mathcal{W} \longrightarrow \mathbf{Q}_p \quad (2.5)$$

such that

$$\zeta_{K/F, S, p}(\sigma, n) = \zeta_{K/F, S}(\sigma, n) \in \mathbf{Q} \quad (2.6)$$

¹Write $q = p$ if p is odd and $q = 4$ if $p = 2$. There is an isomorphism $\mathcal{W} \cong (\mathbf{Z}/q\mathbf{Z})^\times \times (1 + p\mathbf{Z}_p)^\times$ given by $f \mapsto (f(\zeta), f(1+q))$, where ζ is a primitive q -th root of unity in \mathbf{Z}_p^\times . Furthermore, $(1 + p\mathbf{Z}_p)^\times \cong \mathbf{Z}_p$ via the p -adic logarithm map. Therefore, \mathcal{W} can be viewed as $\varphi(q)$ copies of the p -adic space \mathbf{Z}_p . Note that our weight space \mathcal{W} is only a piece of the larger weight space of continuous group homomorphisms $f : \mathbf{Z}_p^\times \rightarrow \mathbf{C}_p^\times$; however, our definition will suffice for our purposes.

for integers $n \leq 0$. The function $\zeta_{S,p}$ is regular away from $s = 1$, and has at most a simple pole at $s = 1$; Colmez has shown that the existence of this pole at $s = 1$ is equivalent to the Leopoldt conjecture for F [6].

Gross's conjecture states that whereas the classical values $\zeta'_{S,K/F}(\sigma, 0)$ determine the \mathfrak{p} -adic valuations of the units u^σ , the p -adic zeta values $\zeta'_{S,K/F,p}(\sigma, 0)$ determine the \mathfrak{p} -adic logarithms of the (norms of the) units u^σ . To make this precise, we consider the branch $\log_p : \mathbf{Q}_p^\times \rightarrow \mathbf{Z}_p$ of the p -adic logarithm for which $\log_p(p) = 0$. Next, fix a place \mathfrak{P} of K above \mathfrak{p} , and consider the composition of the norm map from $K_{\mathfrak{P}}^\times$ to \mathbf{Q}_p^\times with \log_p :

$$\log_p \circ \text{Norm}_{K_{\mathfrak{P}}/\mathbf{Q}_p} : K_{\mathfrak{P}}^\times \rightarrow \mathbf{Z}_p.$$

Via the canonical embeddings $U_{\mathfrak{p},S} \subset K \subset K_{\mathfrak{P}}$, we may restrict the function $\log_p \circ \text{Norm}_{K_{\mathfrak{P}}/\mathbf{Q}_p}$ to a homomorphism from the finitely generated abelian group $U_{\mathfrak{p},S}$ to \mathbf{Z}_p , and extend by scalars to a map

$$\log_p \circ \text{Norm}_{K_{\mathfrak{P}}/\mathbf{Q}_p} : U_{\mathfrak{p},S} \otimes \mathbf{Q} \rightarrow \mathbf{Q}_p.$$

As demonstrated in Proposition 1.7, we may consider the image of u^σ in $U_{\mathfrak{p},S} \otimes \mathbf{Q}$ unconditionally. Gross's conjecture from [15] then states:

Conjecture 2.2 (Gross, weak form). *For each $\sigma \in G$ we have*

$$\zeta'_{K/F,S,p}(\sigma, 0) = -\log_p \text{Norm}_{K_{\mathfrak{P}}/\mathbf{Q}_p}(u^\sigma).$$

We call Conjecture 2.2 the “weak” Gross conjecture and Conjecture 2.1 the “strong” Gross conjecture, since, as was known to Gross, Conjecture 2.1 implies Conjecture 2.2. See [11] for a proof of this fact.

In [9], Conjecture 2.2 was proven under certain assumptions. If F is a real quadratic field and K is a narrow ring class extension of F , then these assumptions hold automatically, and hence the proof is unconditional.

We conclude this section with a T -smoothed version of Conjecture 2.2 for future reference. Define T -smoothed p -adic ζ -functions $\zeta_{K/F,S,T,p}(\sigma, s)$ from the p -adic ζ -functions $\zeta_{K/F,S,p}(\sigma, s)$ using the group ring equation (1.4), with s now an element of \mathcal{W} . Conjecture 2.2 yields:

Conjecture 2.3 (Gross, weak form, T -smoothed). *Assume Conjecture 1.2 with $v = \mathfrak{p}$ and $w = \mathfrak{P}$. For each $\sigma \in G$ we have*

$$\zeta'_{K/F,S,T,p}(\sigma, 0) = -\log_p \text{Norm}_{K_{\mathfrak{P}}/\mathbf{Q}_p}(u_T^\sigma).$$

Chapter 3

Shintani's method

In the 1970s, Shintani introduced a powerful technique for analyzing zeta functions associated to number fields, allowing him to give new proofs that Hecke L -functions admit meromorphic continuation and that values of L -functions of totally real fields at negative integers are algebraic. His analysis is based on an ingenious generalization of Riemann's first proof of the meromorphic continuation of $\zeta(s)$. To emphasize this analogy, we recall some elements of Riemann's method.

3.1 Hurwitz zeta functions

The Riemann zeta function has the remarkable property that its values at nonpositive integers can be packaged into a simple generating function:

$$\frac{z}{e^z - 1} = 1 + \sum_{n=1}^{\infty} \frac{(-1)^n \zeta(1-n)}{(n-1)!} z^n.$$

Equivalently, we have

$$\zeta(1-n) = -\frac{B_n}{n} \quad (n \geq 1),$$

where the *Bernoulli numbers* B_n are defined by the Taylor expansion

$$\frac{z}{e^z - 1} = \sum_{n=0}^{\infty} B_n \frac{z^n}{n!}.$$

This formula has many applications, in particular to p -adic interpolation of the values of $\zeta(s)$ at negative integers. Shintani's zeta functions form a very general class of zeta functions sharing the property that their values at negative integers can be packaged into a nice generating function. Before discussing Shintani's zeta functions themselves, we consider the important special case of Hurwitz zeta functions. The properties of Hurwitz zeta functions will be used in our analysis of general Shintani zeta functions.

Let $\xi \in \mathbf{R}_{>0}$ and $\alpha = (\alpha_1, \dots, \alpha_d)$ be a vector such that $\alpha_i > 0$ for all i . Define the *multiple Hurwitz zeta function* by

$$\zeta(\alpha, \xi, s) = \sum_{k \in \mathbf{Z}_{\geq 0}^d} (\xi + \langle k, \alpha \rangle)^{-s}.$$

It is easy to see that the convergence behaviour of the series above is the same as that of the Dirichlet series

$$\sum_{k \in \mathbf{Z}_{>0}} (k - 1 + \dots + k_d)^{-\sigma} = \sum_{n=1}^{\infty} s_{n,d} n^{-\sigma}, \quad (3.1)$$

where $s_{n,d}$ is the number of ways of writing n as a sum of d positive integers. We have the trivial bound $s_{n,d} \leq n^{d-1}$, from which it follows that the series (3.1), and hence that defining $\zeta(\alpha, \xi, s)$, converges absolutely for $\operatorname{Re}(s) > d$. In fact, it will follow from our study that the exponent $d - 1$ in our approximation of $s_{n,d}$ is optimal, i.e., $s_{n,d} \neq O(n^{d-1-\varepsilon})$ for any $\varepsilon > 0$. (Exercise: Prove this using elementary methods.)

The analytic continuation of $\zeta(\alpha, \xi, s)$ can be established using Riemann's method. As observed by Euler, the change of variable $t \rightarrow \xi + \langle k, \alpha \rangle$ shows that

$$\Gamma(s)(\xi + \langle k, \alpha \rangle)^{-s} = \int_0^{\infty} e^{-(\xi + \langle k, \alpha \rangle)t} t^{s-1} dt,$$

where

$$\Gamma(s) = \int_0^{\infty} e^{-t} t^{s-1} dt, \quad \operatorname{Re}(s) > 0.$$

Therefore, for $\operatorname{Re}(s) > d$ we have

$$\begin{aligned} \Gamma(s)\zeta(\alpha, \xi, s) &= \sum_{k \in \mathbf{Z}_{\geq 0}^d} \int_0^{\infty} e^{-(\xi + \langle k, \alpha \rangle)t} t^{s-1} dt \\ &= \int_0^{\infty} e^{-\xi t} \sum_{k \in \mathbf{Z}_{\geq 0}^d} e^{-\langle k, \alpha \rangle t} t^{s-1} dt \\ &= \int_0^{\infty} e^{-\xi t} \left(\prod_{i=1}^d \sum_{k_i=0}^{\infty} e^{-\alpha_i k_i t} \right) t^{s-1} dt \\ &= \int_0^{\infty} e^{-\xi t} \left(\prod_{i=1}^d \frac{e^{\alpha_i t}}{e^{\alpha_i t} - 1} \right) t^{s-1} dt \end{aligned}$$

For $\varepsilon > 0$, we let $C(\infty, \varepsilon)$ be the *Hankel contour* — the path that traces the real axis from ∞ to ε , circles the origin counterclockwise along $|z| = \varepsilon$, and then retraces the real axis from ε to ∞ . (See Figure 3.1.)

Suppose $\varepsilon < \frac{1}{2}(2\pi / \min\{\alpha_i\})$. We choose the branch of $\log(z)$ such that $0 \leq \arg(z) < 2\pi$. Then the function

$$I(s) = I(\alpha, \xi, s) := \int_{C(\infty, \varepsilon)} e^{-\xi z} \left(\prod_{i=1}^d \frac{e^{\alpha_i z}}{e^{\alpha_i z} - 1} \right) z^{s-1} dz \quad (3.2)$$

Figure 3.1: the Hankel contour

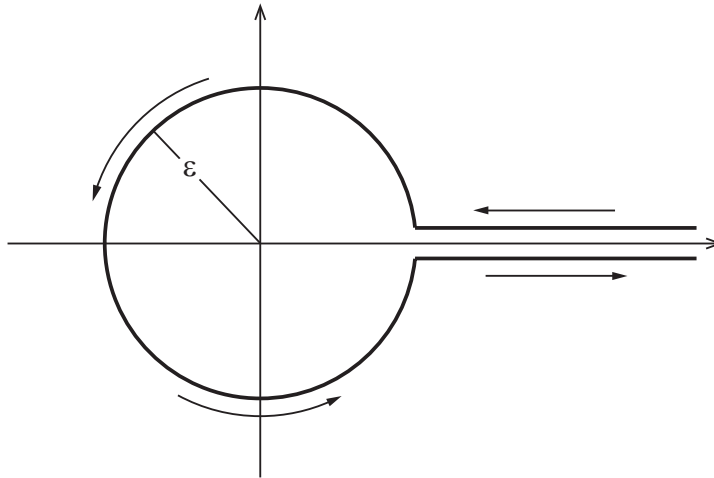

defines an entire function on \mathbf{C} so long as we agree that $\arg(z) = 0$ on the portion of the Hankel contour from $z = +\infty$ to $z = \varepsilon$, and that $\arg(z) = 2\pi$ on the return trip from $z = \varepsilon$ to $z = +\infty$. (Alternatively, we can view the integration as taking place on the universal cover of $\mathbf{C} - \{0\}$.) The function $I(s)$ is independent of ε taken in the given range, because the integrand in (3.2) is holomorphic in any annulus centered at the origin with radii given by two such ε .

Moreover, we have

$$I(s) = (e^{2\pi is} - 1) \int_{\varepsilon}^{\infty} e^{-\xi t} \left(\prod_{i=1}^d \frac{e^{\alpha_i t}}{e^{\alpha_i t} - 1} \right) t^{s-1} dt + \int_{|z|=\varepsilon} e^{-\xi z} \left(\prod_{i=1}^d \frac{e^{\alpha_i z}}{e^{\alpha_i z} - 1} \right) z^{s-1} dz.$$

If $\operatorname{Re}(s) > 1$, then

$$\lim_{\varepsilon \rightarrow 0} \int_{|z|=\varepsilon} e^{-\xi z} \left(\prod_{i=1}^d \frac{e^{\alpha_i z}}{e^{\alpha_i z} - 1} \right) z^{s-1} dz = 0.$$

Therefore, we have

$$\zeta(\alpha, \xi, s) = c_1(s)I(s), \quad c_1(s) := \frac{1}{\Gamma(s)(e^{2\pi is} - 1)} \quad (3.3)$$

for $\operatorname{Re}(s) > d$. Since $Z(s)$ is entire and $\Gamma(s)$ admits a meromorphic continuation to \mathbf{C} , $\zeta(\alpha, x, s)$ can be meromorphically continued as well, with polar set contained in \mathbf{Z} .

Exercise 3.1. Show that $\zeta(\alpha, \xi, s)$ has simple poles at $s = 1, 2, \dots, d$ and is analytic at integers $n > d$. Compute the residues at $s = 1, 2, \dots, d$. Conclude that the series defining $\zeta(\alpha, \xi, s)$ does not converge in the half-plane $\operatorname{Re}(s) > \sigma$ for any $\sigma < d$.

3.2 The Hurwitz zeta functions at nonpositive integers

In this section, we derive formulas for $\zeta(\xi, \alpha, 1 - n)$, $n \geq 1$, when ξ has the form $\xi = \langle \alpha, x \rangle$ for some $x \in \mathbf{R}_{\geq 0}^n$, $x \neq 0$.

It is a standard fact that

$$\lim_{s \rightarrow -m} (s + m)\Gamma(s) = \frac{(-1)^m}{m!}$$

for nonnegative integers m . It follows that

$$\lim_{s \rightarrow -m} \frac{1}{\Gamma(s)(e^{2\pi i s} - 1)} = \frac{(-1)^m m!}{2\pi i}.$$

Adapting (3.3), we have

$$\zeta(\alpha, \langle \alpha, x \rangle, s) = \frac{1}{\Gamma(s)(e^{2\pi i s} - 1)} \int_{C(\infty, \varepsilon)} \prod_{i=1}^d \frac{e^{(1-x_i)\alpha_i z}}{e^{\alpha_i z} - 1} z^{s-1} dz. \quad (3.4)$$

By the residue theorem, if $n \geq 1$, then

$$\begin{aligned} \zeta(\alpha, \langle \alpha, x \rangle, 1 - n) &= \frac{(-1)^{n-1}(n-1)!}{2\pi i} \cdot 2\pi i \operatorname{res}_{z=0} \left(\prod_{i=1}^d \frac{e^{(1-x_i)\alpha_i z}}{e^{\alpha_i z} - 1} z^{-n} \right) \\ &= \frac{(-1)^{n-1}(n-1)!}{\prod_{i=1}^d \alpha_i} \operatorname{coeff}(F(z), n + d - 1), \end{aligned} \quad (3.5)$$

where

$$F(z) = \prod_{i=1}^d \frac{\alpha_i z e^{(1-x_i)\alpha_i z}}{e^{\alpha_i z} - 1}.$$

The Taylor coefficients of $F(z)$ are essentially values of the *Bernoulli polynomials*, defined by the expansion

$$\frac{ze^{xz}}{e^z - 1} = \sum_{n=0}^{\infty} B_n(x) \frac{z^n}{n!}.$$

We have the identity of power series

$$F(z) = \prod_{i=1}^d \sum_{n=0}^{\infty} \frac{B_n(1-x_i)\alpha_i^n}{n!} z^n. \quad (3.6)$$

Combining (3.5) and (3.6), we obtain a useful formula for $\zeta(\alpha, \langle \alpha, x \rangle, 0)$:

$$\zeta(\alpha, \langle \alpha, x \rangle, 0) = (-1)^d \sum_{\substack{r_1 + \dots + r_d = d \\ r_j \in \mathbf{Z}_{\geq 0}}} \prod_{j=1}^d \frac{\alpha_j^{r_j-1}}{r_j!} B_{r_j}(x_j). \quad (3.7)$$

Here we have used the fact that $B_r(1-x) = (-1)^r B_r(x)$. Since the Bernoulli polynomials have rational coefficients, we have established the following result:

Proposition 3.2. *The values $\zeta(x, \alpha, 1 - n)$, $n \geq 1$, belong to the field $\mathbf{Q}(\{x_i\}, \{\alpha_i\})$.*

3.2.1 The multiple Γ -function

Finally, recall the classical Hurwitz zeta function $\zeta_H(x, s)$ discussed in §1.1. The *Lerch formula* relates the derivative of $\zeta_H(x, s)$ at $s = 0$ to the Γ -function:

$$\frac{\partial}{\partial s} \zeta_H(x, s) \Big|_{s=0} = \log \left(\frac{\Gamma(x)}{\sqrt{2\pi}} \right).$$

Motivated by this formula, we define the *multiple Γ -function* $\Gamma(x, \alpha)$ by

$$\log \Gamma(\alpha, \xi) = \frac{\partial}{\partial s} \zeta(\alpha, \xi, s) \Big|_{s=0}.$$

Note that

$$\Gamma(x) = \sqrt{2\pi} \Gamma(x, 1).$$

The multiple log- Γ -function admits meromorphic continuation in ξ to \mathbf{C} . To see this, we differentiate (3.2) under the integral sign to obtain

$$I'(\alpha, \xi, 0) = \int_{C(\infty, \varepsilon)} e^{-\xi z} \left(\prod_{i=1}^d \frac{e^{\alpha_i z}}{e^{\alpha_i z} - 1} \right) \log(z) \frac{dz}{z}. \quad (3.8)$$

Combined with (3.3), this yields

$$\log \Gamma(\alpha, \xi) = c'_1(0) I(\alpha, \xi, 0) + c_1(0) \int_{C(\infty, \varepsilon)} e^{-\xi z} \left(\prod_{i=1}^d \frac{e^{\alpha_i z}}{e^{\alpha_i z} - 1} \right) \log(z) \frac{dz}{z}. \quad (3.9)$$

The function $I(\alpha, \xi, 0)$ is meromorphic in ξ , as is the function defined by the integral on the right. The meromorphic continuability of $\log \Gamma(\alpha, \xi)$ follows.

3.3 Shintani zeta functions

Shintani axiomatized and enlarged the class of functions whose meromorphic continuation can be established using the techniques of the previous subsection plus an ingenious change of variable. Let $a = (a_i^j) \in M_{n \times d}(\mathbf{C})$ such that $\operatorname{Re}(a_i^j) > 0$ for all i, j and let $x \in \mathbf{R}_{\geq 0}^d$ be a nonzero column vector. We write a_i and a^j i -th row and the j -th column of a , respectively. Define the *Shintani zeta function*

$$\zeta(a, x, s) = \sum_{k \in \mathbf{Z}_{\geq 0}^d} N(a(x+k))^{-s} \quad (\operatorname{Re}(s) > d/n), \quad (3.10)$$

where x and k are viewed as column vectors, and the “norm” Nv of a vector $v \in \mathbf{R}^n$ is defined to be

$$Nv = v_1 \cdots v_n.$$

Remark 3.3. If F is a number field of degree n and $x \mapsto x_i$ are the embeddings of F into \mathbf{C} , then $Nx = N_{F/\mathbf{Q}}(x)$.

The multiple Hurwitz zeta function is simply the special case $n = 1$ of the Shintani zeta function.

The convergence of the series (3.10) is governed by that of

$$\sum_{k \in \mathbf{Z}_{>0}} (k_1 + \cdots + k_d)^{-n\sigma}.$$

By the discussion of the previous section, this series converges absolutely when $n\sigma > d$, or equivalently, when $\sigma > d/n$.

By Euler's trick, we obtain

$$\int_0^\infty e^{-a_i(x+k)t_i} t_i^{s-1} dt_i = \Gamma(s) (a_i(x+k))^{-s}. \quad (3.11)$$

We write t for the row vector (t_1, \dots, t_n) and $t^{s-1} dt$ for $(t_1 \cdots t_n)^{s-1} dt_1 \cdots dt_n$. Taking the product of (3.11) over $i = 1, \dots, n$, we are led to

$$\begin{aligned} \Gamma(s)^n \mathbf{N}(a(x+k))^{-s} &= \int_{(0,\infty)^n} e^{-ta(x+k)} t^{s-1} dt \\ &= \int_{(0,\infty)^n} e^{-tax} e^{-tak} t^{s-1} dt. \end{aligned}$$

Summing over k , we have

$$\Gamma(s)^n \zeta(a, x, s) = \int_{(0,\infty)^n} e^{-tax} \sum_{k \in \mathbf{Z}_{\geq 0}^m} e^{-tak} t^{s-1} dt.$$

Noting the geometric series

$$\sum_{k \in \mathbf{Z}_{\geq 0}^d} e^{-tak} = \prod_{j=1}^d \frac{1}{1 - e^{-ta^j}} = \prod_{j=1}^d \frac{e^{ta^j}}{e^{ta^j} - 1},$$

we have

$$\Gamma(s)^n \zeta(a, x, s) = \int_{(0,\infty)^n} G(t) t^{s-1} dt,$$

where

$$G(t) = e^{-tax} \prod_{j=1}^d \frac{e^{ta^j}}{e^{ta^j} - 1} = \prod_{j=1}^d \frac{e^{ta^j(1-x_j)}}{e^{ta^j} - 1}. \quad (3.12)$$

It is tempting to attempt to adapt Riemann's Hankel contour method for obtaining a meromorphic continuation of $\zeta(a, x, s)$ to the complex plane. Unfortunately, a direct application of the method fails: the hyperplane $(a^j)^\perp \subset \mathbf{C}^n$ has positive dimension if $n > 1$, and thus intersects any polydisk centred at $0 \in \mathbf{C}^n$. Therefore, $G(t)$ will have a singularity along $C(\infty, \varepsilon_1) \times \cdots \times C(\infty, \varepsilon_n)$ for all choices of $\varepsilon_i > 0$. Shintani circumvented these analytic

difficulties by decomposing the domain $\mathbf{R}_{>0}^n$ of integration and applying a change of variable. We describe his method. Set

$$D_k = \{(t_1, \dots, t_n) \in \mathbf{R}_{>0}^n : t_j \leq t_k \text{ for all } j\},$$

and

$$z_k(a, x, s) = \Gamma(s)^{-n} \int_{D_k} G(t) t^{s-1} dt. \quad (3.13)$$

We have

$$\mathbf{R}_{>0}^n = \prod_{k=1}^n D_k \quad \text{and} \quad \zeta(a, x, s) = \sum_{k=1}^n z_k(a, x, s). \quad (3.14)$$

Consider the change of variable

$$t = uy = u(y_1, \dots, y_n), \quad t \in D_k,$$

where $u = t_k > 0$. Since $t \in D_k$, we have $0 \leq y_j \leq 1$ for all j and $y_k = 1$. Substituting in (3.14), we have

$$z_k(x, a, s) = \Gamma(s)^{-n} \int_{(0, \infty)} u^{ns-1} \left\{ \int_{(0,1)^{n-1}} G(uy) \hat{y}^{s-1} d\hat{y} \right\} du, \quad (3.15)$$

where we have written

$$y = (y_1, \dots, y_{k-1}, 1, y_{k+1}, \dots, y_n) \in \mathbf{R}^n, \quad \hat{y} = (y_1, \dots, y_{k-1}, y_{k+1}, \dots, y_n) \in \mathbf{R}^{n-1},$$

and

$$\hat{y}^{s-1} d\hat{y} := \prod_{j \neq k} y_j^{s-1} dy_j.$$

Set

$$c_n(s) = \frac{1}{(e^{2\pi i n s} - 1)(e^{2\pi i s} - 1)^{n-1} \Gamma(s)^n} \quad (3.16)$$

and let $C(1, \varepsilon)$ be the subcontour of $C(\infty, \varepsilon)$ that starts and ends at $z = 1$ instead of at $z = +\infty$.

Proposition 3.4. *For sufficiently small ε , we have*

$$z_k(a, x, s) = c_n(s) \int_{C(\infty, \varepsilon)} u^{ns-1} \left\{ \int_{C(1, \varepsilon)^{n-1}} G(uy) \hat{y}^{s-1} d\hat{y} \right\} du. \quad (3.17)$$

The iterated line integral on the right is absolutely convergent and defines a meromorphic function of s that is independent of ε , provided ε is sufficiently small.

Proof. Set

$$I_{k, \varepsilon}(s) = I_{k, \varepsilon}(a, x, s) = \int_{C(\infty, \varepsilon)} u^{ns-1} \left\{ \int_{C(1, \varepsilon)^{n-1}} G(uy) \hat{y}^{s-1} d\hat{y} \right\} du. \quad (3.18)$$

First we verify that, for sufficiently small epsilon, the integrand has no singularities along $C(\infty, \varepsilon) \times C(1, \varepsilon)^{n-1}$. We must show that, for ε sufficiently small, uya^j is not an integer multiple of $2\pi i$. By the Cauchy-Schwartz inequality, we can find $\varepsilon_1 > 0$ such that

$$|uya^j| \leq \|uy\| \cdot \|a^j\| < 1 \quad (j = 1, \dots, d),$$

whenever $|u| < \varepsilon_1$. On the other hand,

$$\lim_{\hat{y} \rightarrow 0} ya^j = a_k^j.$$

Therefore, we may find $\varepsilon_2 > 0$ such that

$$\operatorname{Re}(ya^j) > \frac{1}{2} \min\{\operatorname{Re}(a_i^j) : i = 1, \dots, n\} > 0, \quad j = 1, \dots, d,$$

whenever $|y_i| < \varepsilon_2$ for all $i \neq k$. (This is where we use our assumption that the entries of a have positive real part.) In particular, ya^j is nonzero for these y . Letting $\varepsilon_0 = \min\{\varepsilon_1, \varepsilon_2\}$, we have $0 < |uya^j| < 1$ whenever $|u| < \varepsilon_1$ and $|y_i| < \varepsilon_1$ for all $i \neq k$. Thus, uya^j is not a multiple of $2\pi i$ for these u, y , and the holomorphy of $I_{k,\varepsilon}(s)$ follows. Cauchy's theorem implies that $I_{k,\varepsilon}(s)$ is independent of ε for $\varepsilon < \varepsilon_0$. Therefore, we may denote this function simply by $I_k(s) = I_k(a, x, s)$.

Let $\varepsilon < \varepsilon_0$. By arguments similar to those of the previous section,

$$I_k(s) = \int_{|u|=\varepsilon} u^{ns-1} \left\{ \int_{\substack{|y_i|=\varepsilon \\ i \neq k}} G(uy) \hat{y}^{s-1} d\hat{y} \right\} du + \\ (e^{2\pi ins} - 1)(e^{2\pi is} - 1)^{n-1} \int_{(\varepsilon, \infty)} u^{ns-1} \left\{ \int_{(\varepsilon, 1)^{n-1}} G(uy) \hat{y}^{s-1} d\hat{y} \right\} du.$$

If $s > d/n$, then a trivial estimate shows that

$$\lim_{\varepsilon \rightarrow 0} \int_{|u|=\varepsilon} u^{ns-1} \left\{ \int_{\substack{|y_i|=\varepsilon \\ i \neq k}} G(uy) \hat{y}^{s-1} d\hat{y} \right\} du = 0.$$

Therefore,

$$I_k(s) = (e^{2\pi ins} - 1)(e^{2\pi is} - 1)^{n-1} \int_{(0, \infty)} u^{ns-1} \left\{ \int_{(0, 1)^{n-1}} G(uy) y^{s-1} dy \right\} du \\ = (e^{2\pi ins} - 1)(e^{2\pi is} - 1)^{n-1} \Gamma(s)^n z_k(a, x, s) \\ = c_n(s)^{-1} z_k(a, x, s). \quad \square$$

Exercise 3.5. Find the poles of $\zeta(a, x, s)$, their orders, and their residues.

Exercise 3.6. Show how to define and meromorphically continue the more general Shintani zeta function

$$\zeta(a, x, (s_1, \dots, s_n)) = \sum_{k \in \mathbf{Z}_{\geq 0}^d} \prod_{i=1}^n (a_i(x+k))^{-s_i}.$$

3.4 Special values of Shintani zeta functions

In this section, we give Shintani's formulas for the values of $\zeta(a, x, s)$ when s is a nonpositive integer. We first consider the special case $s = 0$, particularly important from the point of view of Stark's conjecture. The residue of $\Gamma(s)$ at $s = 0$ is 1, and hence

$$\lim_{s \rightarrow 0} c_n(s) = \frac{1}{n(2\pi i)^n}, \quad c_n(s) := \frac{1}{(e^{2\pi i n s} - 1)(e^{2\pi i s} - 1)^{n-1} \Gamma(s)^n}.$$

Therefore, (3.17) becomes

$$z_k(a, x, 0) = \frac{1}{n(2\pi i)^n} I_k(0) = \frac{1}{n(2\pi i)^n} \int_{C(\infty, \varepsilon)} u^{-1} \left\{ \int_{C(1, \varepsilon)^{n-1}} G(uy) \hat{y}^{-1} d\hat{y} \right\} du.$$

Observe that $G(uy)$ is holomorphic in the variables y_i , $i \neq k$. Therefore, by the residue theorem,

$$\begin{aligned} \int_{C(1, \varepsilon)^{n-1}} G(uy) \prod_{i \neq k} \frac{dy_i}{y_i} &= G(0, \dots, 0, u, 0, \dots, 0) \\ &= (2\pi i)^{n-1} \prod_{j=1}^d \frac{e^{(1-x_j)a_k^j u}}{e^{a_k^j u} - 1}. \end{aligned} \quad (3.19)$$

Thus, by (3.4) and (3.7),

$$\begin{aligned} z_k(a, x, 0) &= \frac{1}{n(2\pi i)} \int_{C(\infty, \varepsilon)} \prod_{j=1}^d \frac{e^{(1-x_j)a_k^j u}}{e^{a_k^j u} - 1} \frac{du}{u} \\ &= \frac{1}{n} \zeta(a_k, \langle a_k, x \rangle, 0) \end{aligned} \quad (3.20)$$

$$= \frac{(-1)^d}{n} \sum_{\substack{\ell \in \mathbf{Z}_{\geq 0}^d \\ \ell_1 + \dots + \ell_d = d}} \prod_{j=1}^d B_{\ell_j}(x_j) \frac{(a_k^j)^{\ell_j - 1}}{\ell_j!}. \quad (3.21)$$

Proposition 3.7. *We have:*

$$\zeta(a, x, 0) = \frac{(-1)^d}{n} \sum_{k=1}^n \sum_{\substack{\ell \in \mathbf{Z}_{\geq 0}^d \\ \ell_1 + \dots + \ell_d = d}} \prod_{j=1}^d B_{\ell_j}(x_j) \frac{(a_k^j)^{\ell_j - 1}}{\ell_j!}. \quad (3.22)$$

Corollary 3.8. *The value $\zeta(a, x, 0)$ belongs to the field generated by the components of x and the entries of a .*

We record the $n = d = 2$ case of this formula for later use. Writing

$$w = \begin{pmatrix} w_1 \\ w_2 \end{pmatrix}, \quad a = \begin{pmatrix} p & q \\ r & s \end{pmatrix},$$

we have

$$\zeta(a, w, 0) = \frac{1}{4} \left\{ \left(\frac{p}{q} + \frac{r}{s} \right) B_2(w_1) + 4B_1(w_1)B_2(w_2) + \left(\frac{q}{p} + \frac{s}{r} \right) B_2(w_2) \right\}. \quad (3.23)$$

3.4.1 Generalized Bernoulli polynomials

To evaluate $\zeta(a, x, 1 - n)$ for $n \geq 1$, we define generalized Bernoulli polynomials $B_{k,m}(a, x)$ by

$$\frac{B_{k,m}(a, \mathbf{1} - x)}{(m!)^n} = \text{coeff} \left(G(uy), (u^n y_1 \cdots y_{k-1} y_{k+1} \cdots y_n)^{m-1} \right), \quad (3.24)$$

where $\mathbf{1}$ is the vector $(1, \dots, 1)$.

Theorem 3.9 ([26, Proposition 1]). *Let $m \geq 1$ be an integer. Then*

$$\zeta(a, x, 1 - m) = \frac{(-1)^{n(m-1)}}{n} \sum_{k=1}^n \frac{B_{k,m}(a, \mathbf{1} - x)}{m^n}.$$

Proof. Applying the residue theorem a total of n times, we have

$$\begin{aligned} I_{k,\varepsilon}(1 - m) &= \int_{C(\infty,\varepsilon)} u^{n(1-m)-1} \left\{ \int_{C(1,\varepsilon)^{n-1}} G(uy) \hat{y}^{-m} d\hat{y} \right\} du \\ &= 2\pi i \text{coeff} \left((2\pi i)^{n-1} \text{coeff} \left(G(uy), \hat{y}^{m-1} \right), u^{n(m-1)} \right) \\ &= (2\pi i)^n \frac{B_{k,m}(a, \mathbf{1} - x)}{(m!)^n}. \end{aligned}$$

Since

$$\lim_{s \rightarrow 1-m} (e^{2\pi i n s} - 1)(e^{2\pi i s} - 1)^{n-1} \Gamma(s)^n = n \left(\frac{(-1)^{m-1} 2\pi i}{(m-1)!} \right)^n$$

we conclude using Proposition 3.4 that

$$z_k(a, x, 1 - m) = \frac{(-1)^{n(m-1)}}{n} \frac{B_{k,m}(\mathbf{1} - x)}{m^n}.$$

The desired result follows from (3.14). □

Exercise 3.10. *Express the generalized Bernoulli polynomial $B_{k,m}(a, x)$ in terms of the standard Bernoulli polynomials B_k .*

Corollary 3.11. *The value $\zeta(a, x, 1 - m)$ belongs to the field generated by the components of x and the entries of a .*

3.4.2 An algebraic version of Shintani's formula

Recall that the singularity of

$$G(t) = \prod_{j=1}^d \frac{e^{(1-x_j)ta^j}}{e^{ta^j} - 1}.$$

at $t = 0$ is not isolated, implying that $G(t)$ does not have a convergent Laurent expansion in any punctured neighbourhood of $t = 0$. Nevertheless, for $j = 1, \dots, d$, we may define

$$G^j(t) = \begin{cases} \frac{ta^j}{e^{ta^j} - 1} & \text{if } ta^j \neq 0, \\ 1, & \text{otherwise.} \end{cases}$$

The functions $G^j(t)$ are holomorphic at $t = 0$ and thus have convergent Taylor expansions

$$G^j(t) \in \mathbf{C}[[t]] := \mathbf{C}[[t_1, \dots, t_n]].$$

Since $\prod_{j=1}^d ta^j \in \mathbf{C}[t] \subset \mathbf{C}[[t]]$, we may identify $G(t)$ as a quotient

$$G(t) = \prod_{j=1}^d \frac{G^j(t)e^{(1-x_i)ta^j}}{ta^j} \in \mathbf{C}((t)),$$

where $\mathbf{C}((t))$ denotes the field of fractions of $\mathbf{C}[[t]]$. Caution is required when working with the field $\mathbf{C}((t))$ because, unless $n = 1$, its elements are not simply formal sums of monomials t^m , $m \in \mathbf{Z}^n$. In particular, it does not make sense to talk about the coefficient of t^m appearing in a general element of $\mathbf{C}((t))$ when $n > 1$. However, we make the following trivial observation:

Lemma 3.12. *Let $h(t) \in \mathbf{C}[t]$ be a homogeneous polynomial of degree r such that*

$$\text{coeff}(h(t), t_k^r) \neq 0,$$

let $g(t) \in \mathbf{C}[[t]]$, and let $f(t) = g(t)/h(t)$. Then

$$f(t_k(t_1, \dots, t_{k-1}, 1, t_{k+1}, \dots, t_n)) \in t_k^{-r} \mathbf{C}[[t]].$$

If $f(t)$ is as in the lemma, then the expression

$$\text{coeff}(f(t_k(t_1, \dots, t_{k-1}, 1, t_{k+1}, \dots, t_n)), t^m) \tag{3.25}$$

is well defined for all $t \in \mathbf{Z}^n$. Now, $G(t)$ has the property of Lemma 3.12 with $h(t) = \prod_{j=1}^d ta^j$ (recall that each a_i^j has positive real part and in particular is non-zero). Therefore it makes sense to discuss the coefficients (3.25) for the *algebraic* object $G(t) \in \mathbf{C}((t))$; these coefficients encode the values of $\zeta(a, x, s)$ at nonpositive integers, as described in the following corollary.

Corollary 3.13. *Let m be a nonnegative integer. Then*

$$\zeta(a, x, -m) = \Delta^{(m)} G := \frac{((-1)^m m!)^n}{n} \times \sum_{k=1}^n \text{coeff}(G(t_k(t_1, \dots, t_{k-1}, 1, t_k, \dots, t_n)), (t_1 \cdots t_{k-1} t_k^n t_{k+1} \cdots t_n)^m).$$

3.5 Derivatives of Shintani zeta functions at $s = 0$

Recall that by Proposition 3.4, we have

$$z_k(a, x, s) = c_n(s)I_k(a, x, s).$$

(These functions were defined in (3.13), (3.16), and (3.18).) Therefore,

$$\begin{aligned} z'_k(a, x, 0) &= c'_n(0)I_k(a, x, 0) + c_n(0)I'_k(a, x, 0) \\ &= c'_n(0)(2\pi i)^{n-1}I(a_k, \langle a_k, x \rangle, 0) + c_n(0)I'_k(a, x, 0), \end{aligned} \quad (3.26)$$

Differentiating under the integral sign,

$$I'_k(a, x, 0) = n \int_{C(\infty, \varepsilon)} \log(u) \left\{ \int_{C(1, \varepsilon)^{n-1}} G(uy) \frac{d\hat{y}}{\hat{y}} \right\} \frac{du}{u} \quad (3.27)$$

$$+ c_n(0)^{-1} \sum_{i \neq k} \delta_{k,i}(a, x) \quad (3.28)$$

where

$$\delta_{k,i}(a, x) = c_n(0) \int_{C(\infty, \varepsilon)} \int_{C(1, \varepsilon)^{n-1}} G(uy) \log(y_i) \frac{d\hat{y}}{\hat{y}} \frac{du}{u} \quad (i \neq k).$$

By (3.19), the term from (3.27) may be written

$$\begin{aligned} &n(2\pi i)^{n-1} \int_{C(\infty, \varepsilon)} \log(u) \prod_{j=1}^d \frac{e^{(1-x_j)a_k^j u}}{e^{a_k^j u} - 1} \frac{du}{u} \\ &= \frac{n(2\pi i)^{n-1}}{c_1(0)} (\log \Gamma(a_k, \langle a_k, x \rangle) - c'_1(0)I(a_k, \langle a_k, x \rangle, 0)), \end{aligned} \quad (3.29)$$

Here (3.29) follows from (3.9).

Combining (3.26)–(3.29) and applying the identities

$$c_n(0)n(2\pi i)^{n-1} = c_1(0), \quad c'_n(0)(2\pi i)^{n-1} = c'_1(0),$$

we see that

$$z'_k(a, x, 0) = \log \Gamma(a_k, \langle a_k, x \rangle) + \sum_{i \neq k} \delta_{k,i}(a, x). \quad (3.30)$$

The terms $\delta_{k,i}(a, x)$ can be evaluated in “elementary” terms:

$$\delta_{k,i}(a, x) = \frac{(-1)^d}{n} \sum_{j=1}^d \sum_{\substack{\ell \in \mathbf{Z}_{\geq 0}^d \\ \ell_1 + \dots + \ell_d = d \\ \ell_j = 0}} (\log(a_k^j) - \log(a_k^j + a_i^j)) \prod_{r \neq j} \frac{B_{\ell_r}(x_r)}{\ell_r!} \left(\frac{a_k^r}{a_k^j} - \frac{a_i^r}{a_i^j} \right)^{\ell_r - 1}. \quad (3.31)$$

Note that for all i, j, k ,

$$\prod_{r \neq k} \left(\frac{a_k^r}{a_k^j} - \frac{a_i^r}{a_i^j} \right)^{\ell_r - 1} = - \prod_{r \neq k} \left(\frac{a_i^r}{a_i^j} - \frac{a_k^r}{a_k^j} \right)^{\ell_r - 1}.$$

Therefore,

$$\sum_{k=1}^n \sum_{i \neq k} \delta_{k,i}(a, x) = \sum_{k=1}^n \delta_k(a, x),$$

where

$$\delta_k(a, x) = \frac{(-1)^d}{n} \sum_{j=1}^d \sum_{\substack{\ell \in \mathbf{Z}_{\geq 0}^d \\ \ell_1 + \dots + \ell_d = d \\ \ell_j = 0}} \log(a_k^j) \prod_{r \neq j} \frac{B_{\ell_r}(x_r)}{\ell_r!} \left(\frac{a_k^r}{a_k^j} - \frac{a_i^r}{a_i^j} \right)^{\ell_r - 1}, \quad (3.32)$$

and we have

$$z'_k(a, x, 0) = \Gamma(a_k, \langle a_k, x \rangle, 0) + \delta_k(a, x).$$

Combining with (3.14), we obtain

$$\zeta'(a, x, 0) = \sum_{k=1}^n \left(\Gamma(a_k, \langle a_k, x \rangle, 0) + \delta_k(a, x) \right). \quad (3.33)$$

This formula will be used in the construction of Stark units in the ATR case.

3.5.1 The multiple sine function

Suppose now that, in addition to previously imposed hypotheses, we have $0 \leq \operatorname{Re}(x_j) \leq 1$ and $\mathbf{1} - \operatorname{Re}(x) \neq 0$, where $\mathbf{1} = (1, \dots, 1) \in \mathbf{R}^d$. Define

$$\zeta^+(a, x, s) = -\zeta(a, x, s) + (-1)^d \zeta(a, \mathbf{1} - x, s).$$

By 3.7 and the identity

$$B_\ell(t) = (-1)^\ell B_\ell(1 - t), \quad (3.34)$$

we have

$$\zeta^+(a, x, 0) = 0.$$

Thus, it is very natural to consider the derivative of $\zeta^+(a, x, s)$ at $s = 0$. We define the *Shintani sine function* by

$$\mathcal{S}(x, a) = \exp \left(\frac{d}{ds} \zeta^+(x, A, s) \Big|_{s=0} \right).$$

Applying (3.34) again, we see that

$$\delta_k(a, x) + (-1)^d \delta_k(a, \mathbf{1} - x) = 0.$$

Therefore,

$$\mathcal{S}(a, x) = (\zeta^+)'(a, x, 0) = \sum_{k=1}^n (\zeta^+)'(a_k, \langle a_k, x \rangle, 0) = \sum_{k=0}^n \mathcal{S}(a_k, \langle x, a_k \rangle).$$

We will apply this formula later to our study of Stark's conjecture in the TR_∞ case.

3.6 Partial zeta functions

Let F be a number field of degree n with ring of integers \mathcal{O}_F . Let $x \mapsto x_i$, $i = 1, \dots, r_1$ be the real embeddings of F and let $x \mapsto x_i$, $i = r_1 + 1, \dots, r_1 + 2r_2 = n$, be its complex embeddings. We have

$$N_{F/\mathbf{Q}}(x) = \prod_{i=1}^n x_i. \quad (3.35)$$

Fix an ideal \mathfrak{f} and write

$$E(\mathfrak{f}) = \{x \in \mathcal{O}_F^\times : x > 0, x \equiv 1 \pmod{\mathfrak{f}}\},$$

where $x > 0$ is shorthand for $x_i > 0$, $i = 1, \dots, r_1$. Let $a = \{a^1, \dots, a^d\}$ be a set of \mathbf{Q} -linearly independent elements of $F_{>0}$. We define the cone $c(a)$ spanned by a to be

$$c(a) = \left\{ \sum_{i=1}^d x^i a^i : x^i \in \mathbf{Q}_{>0} \text{ for all } i \right\}.$$

The number d is called the dimension of c and will be denoted $d(c)$.

Theorem 3.14 ([26, Proposition 4]). *There exists a finite set \mathcal{C} of pairwise disjoint cones such that:*

1. $F_{>0} = \bigsqcup_{\varepsilon \in E(\mathfrak{f})} \varepsilon \mathcal{D}$, where $\mathcal{D} = \bigsqcup_{c \in \mathcal{C}} c$. Thus, \mathcal{D} is a fundamental domain for the action of $E(\mathfrak{f})$ on $F_{>0}$.
2. For every $c \in \mathcal{C}$ there is a set $\{u_{c,i} : r_1 + 1 \leq i \leq n\} \subset \mathbf{C}$, $|u_{c,i}| = 1$, such that:
 - (a) $\operatorname{Re}(u_{c,i} a_i^j) > 0$ for $i = r_1 + 1, \dots, n$, $j = 1, \dots, d(c)$.
 - (b) If $x \mapsto x_i$ and $x \mapsto x_{i'}$ are complex conjugate embeddings of F into \mathbf{C} , then $u_{c,i} = \bar{u}_{c,i'}$.

In particular, $u_{c,r_1+1} \cdots u_{c,n} = 1$.

The set \mathcal{C} will be called a *Shintani fan*.

Example 3.15. Let $F = \mathbf{Q}(\omega)$, $\omega = \frac{1}{2}(1 + \sqrt{-3})$. Then

$$\mathcal{D} = c(1) \sqcup c(1, \omega)$$

is a fundamental domain for the action of \mathcal{O}_F^\times on F^\times .

Example 3.16. Let F be a real quadratic field. Let ε be a generator of $E(\mathfrak{f})$. Then

$$\mathcal{D} = c(1) \sqcup c(1, \varepsilon)$$

is a fundamental domain for the action of $E(\mathfrak{f})$ on $F_{>0}$.

Let \mathfrak{f} be an integral ideal of F . Let $K = K_{\mathfrak{f}}$ be the narrow ray class field of F associated to the conductor \mathfrak{f} and let S be the set consisting of the infinite primes of F together with the primes dividing \mathfrak{f} . Let $\sigma \in \text{Gal}(K/F)$ and select an ideal $\mathfrak{a} \subset \mathcal{O}_F$, $(\mathfrak{a}, S) = 1$, such that the image of \mathfrak{a} under the Artin map is σ . It is easy to check that

$$(1 + \mathfrak{f}\mathfrak{a}^{-1}) \cap \mathcal{D} \longrightarrow \{x \in 1 + \mathfrak{f}\mathfrak{a}^{-1} : x > 0\} / E(\mathfrak{f})$$

is a bijection. We have

$$\begin{aligned} \zeta_{K/F,S}(\sigma, s) &= \sum_{\substack{\mathfrak{b} \subset \mathcal{O}_F \\ (\mathfrak{b}, S) = 1, \sigma_{\mathfrak{b}} = \sigma_{\mathfrak{a}}}} N\mathfrak{b}^{-s} \\ &= N\mathfrak{a}^{-s} \sum_{\substack{\alpha \in 1 + \mathfrak{a}^{-1}\mathfrak{f}, \alpha > 0 \\ \alpha \bmod E(\mathfrak{f})}} N\alpha^{-s} \end{aligned} \quad (3.36)$$

$$= N\mathfrak{a}^{-s} \sum_{c \in \mathcal{C}} \zeta(\mathfrak{a}, c, s), \quad (3.37)$$

where \mathcal{C} is a Shintani fan and

$$\zeta(\mathfrak{a}, c, s) := \sum_{\alpha \in (1 + \mathfrak{a}^{-1}\mathfrak{f}) \cap c} N\alpha^{-s}.$$

Here (3.36) uses the change of variables $(\alpha) = \mathfrak{b}\mathfrak{a}^{-1}$. Let c be a cone in \mathcal{C} .

Lemma 3.17. *There is a unique \mathbf{Q} -linearly independent subset $\{a^1, \dots, a^{d(c)}\}$ of $\mathfrak{a}^{-1}\mathfrak{f}$ such that $c = c(a)$ and such that $a^j \notin k\mathfrak{a}^{-1}\mathfrak{f}$ for all integers $k > 1$ and all j .*

To this set of generators of c , we associate the parallelepiped

$$P = P_c = \left\{ \sum_{i=1}^{d(c)} x^i a^i : 0 < x^j \leq 1 \text{ for all } j \right\}.$$

Lemma 3.18. *Every $y \in (1 + \mathfrak{a}^{-1}\mathfrak{f}) \cap c$ can be expressed uniquely in the form*

$$y = x + k^1 a^1 + \dots + k^{d(c)} a^{d(c)}$$

for some $x \in P_c$ and $k \in \mathbf{Z}_{\geq 0}^{d(c)}$.

Let $a = a_c$ be the $n \times d(c)$ matrix whose (i, j) -th entry is a_i^j (i.e. the i th archimedean embedding of the element $a^j \in F$) and define

$$u = u_c = \text{diag}(\underbrace{1, \dots, 1}_{r_1}, u_{c, r_1+1}, \dots, u_{c, n}). \quad (3.38)$$

We call u a *rotation matrix* for c . Then the Shintani zeta function $\zeta(ua, x, s)$ is defined for all $x \in (1 + \mathfrak{a}^{-1}\mathfrak{f}) \cap P$ and, by Lemma 3.18, we have

$$\zeta(\mathfrak{a}, c, s) = \sum_{x \in (1 + \mathfrak{a}^{-1}\mathfrak{f}) \cap P_c} \zeta(u_c a_c, [x], s), \quad (3.39)$$

where $[x] \in \mathbf{Q}_{\geq 0}^d$ is the coefficient vector of x with respect to the columns of a_c , i.e. such that $x = \sum_{j=1}^{d(c)} [x]_j a^j$. In (3.39), we have used the fact that $u_{c,r_1+1} \cdots u_n = 1$ along with (3.35). It follows that

$$\zeta_{K/F,S}(\sigma, s) = N\mathfrak{a}^{-s} \sum_{c \in \mathcal{C}} \sum_{x \in (1+\mathfrak{a}^{-1}\mathfrak{f}) \cap P_c} \zeta(u_c a_c, [x], s) \quad (3.40)$$

$$= N\mathfrak{a}^{-s} \sum_{c \in \mathcal{C}} \sum_{x \in (1+\mathfrak{a}^{-1}\mathfrak{f}) \cap P_c} \sum_{k=1}^n z_k(u_c a_c, [x], s). \quad (3.41)$$

Corollary 3.19. *The partial zeta function $\zeta_{K/F,S}(\sigma, s)$ admits a meromorphic continuation to the whole complex plane and takes on rational values at nonpositive integral arguments.*

Exercise 3.20. *Suppose F has at least one complex place and $|S| \geq 2$. Show that $\zeta_S(\sigma, n) = 0$ for $n < 0$. Hint: Think about the gamma factors in the functional equation.*

3.7 Shintani decompositions of partial zeta functions

We can use the decomposition of Shintani zeta functions in (3.14) to decompose $\zeta_S(\sigma, s)$. Define

$$z_k(\mathfrak{a}, \mathcal{C}, \{u_c\}, s) = \sum_{c \in \mathcal{C}} \sum_{x \in (1+\mathfrak{a}^{-1}\mathfrak{f}) \cap P_c} z_k(u_c a_c, [x], s), \quad (3.42)$$

where $[x] \in \mathbf{Q}_{\geq 0}^d$ is the coordinate vector of x with respect to the columns of a_c . As we shall see, the existence of this decomposition is the key to all the conjectural, archimedean Stark unit constructions based on Shintani-type methods. To obtain well-defined candidates for Stark units, we must analyze the dependence of $z_k(\mathfrak{a}, \mathcal{C}, \{u_c\}, 0)$ and $z'_k(\mathfrak{a}, \mathcal{C}, \{u_c\}, 0)$ on the choices of \mathfrak{a} , \mathcal{C} and $\{u_c\}$.

3.7.1 Dependence on rotation matrices

Proposition 3.21. *Suppose u and v are diagonal matrices such that all the entries of au and av have positive real part.*

1. *We have $\zeta(ua, x, 0) = \zeta(va, x, 0)$. More precisely,*

$$\zeta(ua, x, 0) = \frac{(-1)^d}{n} \sum_{k=1}^n \sum_{\substack{\ell \in \mathbf{Z}_{\geq 0}^d \\ \ell_1 + \cdots + \ell_d = d}} \prod_{j=1}^d \frac{B_{\ell_j}(x_j)}{\ell_j!} (a_k^j)^{\ell_j - 1}.$$

2. *Suppose that $a = a_c$ and $u = u_c$ where $c = c(a^1, \dots, a^d)$ is a cone in $F_{>0}$ and that $x \in \mathbf{Q}_{\geq 0}^2$, $x \neq 0$. Then*

$$\zeta(ua, x, 0) = \text{Tr}_{F/\mathbf{Q}} \left(\frac{(-1)^d}{n} \sum_{\substack{\ell \in \mathbf{Z}_{\geq 0}^d \\ \ell_1 + \cdots + \ell_d = d}} \prod_{j=1}^d \frac{B_{\ell_j}(x_j)}{\ell_j!} (a^j)^{\ell_j - 1} \right) \in \mathbf{Q}.$$

3. Let v_c be another rotation matrix for c and let N be a positive integer such that $\zeta(x, ua, 0) \in \frac{1}{N}\mathbf{Z}$. Then

$$z'_k(ua, x, 0) - \zeta(a, x, 0) \log(u_k) \equiv z'_k(va, x, 0) - \zeta(0, a, x) \log(v_k) \pmod{\frac{2\pi i}{N}\mathbf{Z}}$$

for $k = 1, \dots, n$.

Remark 3.22. The formula for $\zeta(ua, x, 0)$ in 1. is the same as that appearing in (3.22). Thus, rotation matrices have no effect on the values of Shintani zeta functions at $s = 0$.

Proof. The deduction of 1. and 2. from previous results is left as an exercise for the reader. For a proof of 3., see [20, Proposition 2] case $v = 1$. \square

Setting

$$\varphi_k(a, u, x) = z'_k(ua, x, 0) - \zeta(ua, x, 0) \log(u_k),$$

$$\Phi_k(\mathbf{a}, \mathcal{C}, \{u_c\}) = \sum_{c \in \mathcal{C}} \sum_{x_c \in (1 + \mathfrak{a}^{-1}\mathfrak{f}) \cap P_c} \varphi_k(a_c, u_c, x_c)$$

we have shown that the cosets $\varphi_k(a, u, x) + \frac{2\pi i}{N}\mathbf{Z}$ and $\Phi_k(\mathbf{a}, \mathcal{C}, \{u_c\}) + \frac{2\pi i}{N}\mathbf{Z}$ are independent of the rotation matrix u . Since rotations corresponding to conjugate embeddings are conjugate, we obtain from (3.41):

$$\sum_{k=1}^n \Phi_k(\mathbf{a}, \mathcal{C}, \{u_c\}) \equiv \zeta'_S(\sigma_{\mathbf{a}}, 0) \pmod{\frac{2\pi i}{N}\mathbf{Z}} \quad (3.43)$$

when $\zeta_{K/F,S}(\sigma_{\mathbf{a}}, 0) = 0$. This decomposition of $\zeta'_S(\sigma_{\mathbf{a}}, 0)$ is the key to the refinement of Stark's conjecture in the ATR case.

3.7.2 Dependence on the cover

We say that $(\mathcal{C}', \{u_{c'}\})$ is a *refinement* or *simplicial subdivision* of $(\mathcal{C}, \{u_c\})$ if

1. \mathcal{C}' can be partitioned into subsets \mathcal{C}'_c , $c \in \mathcal{C}$, such that each c is the disjoint union of the simplicial cones $c' \in \mathcal{C}'_c$;
2. For each $c' \in \mathcal{C}'_c$, we have $u_{c'} = u_c$.

Proposition 3.23.

1. The quantity $\Phi_k(\mathbf{a}, \mathcal{C}, \{u_c\})$ is invariant under refinement of \mathcal{C} .
2. Let $(\mathcal{C}, \{u_c\})$ and $(\mathcal{D}, \{u_d\})$ be as in Theorem 3.14. Then there an unit $\eta \in E(\mathfrak{f})$ such that

$$\Phi_k(\mathbf{a}, \mathcal{D}, \{u_d\}) \equiv \Phi_k(\mathbf{a}, \mathcal{C}, \{u_c\}) - \frac{1}{N} \log \eta_k \pmod{\frac{2\pi i}{N}\mathbf{Z}}.$$

Remark 3.24. The proof of statement 1. is the technical heart of the paper [20].

Proof. Let c be a simplicial, let $a = a_c$ be its matrix of generators, and let $u = u_c$ be an associated rotation matrix. To show that

$$\begin{aligned}\varphi_k(a, u, x) &= z'_k(ua, x, 0) + \zeta(ua, x, 0) \log(u_k) \\ &= \log \Gamma(ua_k, \langle ua_k, x \rangle) + \delta_k(ua, x) + \zeta(ua, x, 0) \log(u_k)\end{aligned}$$

is invariant under simplicial subdivision, we consider its three constituents separately. To show that $\log \Gamma(ua_k, \langle ua_k, x \rangle)$ and $\zeta(ua, x, 0)$ are invariant under simplicial subdivision of c is a routine exercise. Showing that $\delta_k(ua, x)$ is similarly invariant is hard, technical work. We refer the reader to [20, Lemma 1] for details.

We prove 2. As $\bigcup \mathcal{C}$ and $\bigcup \mathcal{D}$ may be different fundamental domains for the action of $E(\mathfrak{f})$ on $F_{>0}$, there need be no common refinement. However, by 1., we may assume the following property is satisfied: For each $c \in \mathcal{C}$ there is a unique unit $\eta_c \in E(\mathfrak{f})$, such that $c\eta_c \in \mathcal{D}$. Since $\bigcup \mathcal{C}$ and $\bigcup \mathcal{D}$ are both fundamental domains for the action of $E(\mathfrak{f})$ on $F_{>0}$, we must have $\mathcal{D} = \{c\eta_c : c \in \mathcal{C}\}$.

Set

$$\delta_c = \text{diag}(\eta_c^{(1)}, \dots, \eta_c^{(n)}), \quad v_c = u_c \delta_c^{-1}.$$

Noting that $a_{c\eta_c} = \delta_c a_c$, we see that the entries of the matrices $v_c a_{c\eta_c} = u_c a_c$ have positive real parts. We have:

$$\begin{aligned}\varphi_k(a_{c\eta_c}, v_c, x) &= \varphi_k(\delta_c a_c, u_c \delta_c^{-1}, x) \\ &\equiv \varphi_k(a_c, u_c, x) - \zeta(u_c a_c, x, 0) \log \eta_c^{(k)} \pmod{\frac{2\pi i}{N} \mathbf{Z}}\end{aligned}$$

by statement 3. of Proposition 3.21. Since $\eta_c \equiv 1 \pmod{\mathfrak{f}}$, we have

$$(1 + \mathfrak{a}^{-1}\mathfrak{f}) \cap P_{c\eta_c} = ((1 + \mathfrak{a}^{-1}\mathfrak{f}) \cap P_c) \eta_c.$$

Therefore,

$$\Phi_k(\mathfrak{a}, \mathcal{D}, \{v_c\}) \equiv \Phi_k(\mathfrak{a}, \mathcal{C}, \{u_c\}) - \sum_{c \in \mathcal{C}} \sum_{(1+\mathfrak{a}^{-1}\mathfrak{f}) \cap P_{c\eta_c}} \zeta(u_c a_c, x, 0) \log(\eta_c^{(k)}) \pmod{\frac{2\pi i}{N} \mathbf{Z}}.$$

For each c and x , let

$$t(c, x) = N \zeta(u_c a_c, x, 0) \in \mathbf{Z}.$$

Then

$$\sum_{c \in \mathcal{C}} \sum_{(1+\mathfrak{a}^{-1}\mathfrak{f}) \cap P_{c\eta_c}} \zeta(u_c a_c, x, 0) \log(\eta_c^{(k)}) = \frac{1}{N} \log \eta^{(k)},$$

where

$$\eta := \prod_{c \in \mathcal{E}} \prod_{(1+\mathfrak{a}^{-1}\mathfrak{f}) \cap P_{c\eta_c}} \eta_c^{t(c,x)},$$

and we have

$$\Phi_k(\mathfrak{a}, \mathcal{D}, \{v_c\}) \equiv \Phi_k(\mathfrak{a}, \mathcal{C}, \{u_c\}) - \frac{1}{N} \log \eta^{(k)} \pmod{\frac{2\pi i}{N} \mathbf{Z}}.$$

This proves 2., completing the proof. \square

3.7.3 Dependence on representative ideal

Proposition 3.25. *Let μ be a totally positive element of F such that $\mu \equiv 1 \pmod{\mathfrak{f}}$. Then*

$$\Phi_k(\mu\mathfrak{a}, \mathcal{C}, \{u_c\}) \equiv \Phi_k(\mathfrak{a}, \mathcal{C}, \{u_c\}) \pmod{\frac{2\pi i}{N}\mathbf{Z}}.$$

Proof. Since $\mu \equiv 1 \pmod{\mathfrak{f}}$, we have $1 + (\mu\mathfrak{a})^{-1}\mathfrak{f} = \mu^{-1}(1 + \mathfrak{a}^{-1}\mathfrak{f})$. Therefore,

$$(1 + (\mu\mathfrak{a})^{-1}\mathfrak{f}) \cap P_c = \mu^{-1}((1 + \mathfrak{a}^{-1}\mathfrak{f}) \cap P_{\mu c})$$

for all $c \in \mathcal{C}$. Consequently,

$$\sum_{x \in (1 + (\mu\mathfrak{a})^{-1}\mathfrak{f}) \cap P_c} \sum_{k \in \mathbf{Z}_{\geq 0}^d} N(a(x+k))^{-s} = \sum_{x \in (1 + \mathfrak{a}^{-1}\mathfrak{f}) \cap P_{\mu c}} \sum_{k \in \mathbf{Z}_{\geq 0}^d} N(a(\mu^{-1}x+k))^{-s}. \quad \square$$

3.8 Kronecker's limit formula and Shintani zeta functions

Let $\tau \in \mathcal{H}$ and let $z = a_1 + a_2\tau$. The *Siegel function* is defined by

$$g_a(\tau) = -q_\tau^{\frac{1}{2}B_2(a_2)} e^{\pi i a_1(a_2-1)} (1 - q_z) \prod_{n=1}^{\infty} (1 - q_\tau^n q_z) (1 - q_\tau^n q_z^{-1})$$

where $q_z = e^{2\pi i z}$ and $q_\tau = e^{2\pi i \tau}$, and $B_2(x) = x^2 - x + 1/6$ is the second Bernoulli polynomial. Suppose $a_1, a_2 \in \frac{1}{N}\mathbf{Z}$. Define

$$f_a(\tau) = g_a(\tau)^{12N}.$$

Theorem 3.26. *The function f_a only depends on the coset $a + \mathbf{Z}^2$. It is a holomorphic modular form of weight 0 for $\Gamma(N)$ with no zeros or poles on \mathcal{H} . The functions f_a , $a \in \frac{1}{N}\mathbf{Z}/\mathbf{Z}$, generate the field function field $\mathbf{Q}(\zeta_N)(X(N))$.*

Let F be an imaginary quadratic field and let $\mathfrak{f} \subset \mathcal{O}_F$ be an ideal, $\mathfrak{f} \neq (1)$. Let S consist of the infinite prime of F together with the primes dividing \mathfrak{f} . Write $K_{\mathfrak{f}}$ for the ray class field of F of conductor \mathfrak{f} , let $\sigma \in \text{Gal}(K_{\mathfrak{f}}/F)$, and let $\mathfrak{a} \subset \mathcal{O}_F$ be an ideal, $(\mathfrak{a}, \mathfrak{f}) = 1$, such that the image of \mathfrak{a} under the Artin map is σ . Suppose

$$\mathfrak{a}^{-1}\mathfrak{f} = \mathbf{Z}\omega_1 + \mathbf{Z}\omega_2 = \omega_1(\mathbf{Z} + \mathbf{Z}\tau), \quad \tau := \omega_2/\omega_1 \in \mathcal{H}.$$

Let f be the smallest positive integer in \mathfrak{f} . Then $1 \in (f\mathfrak{a})^{-1}\mathfrak{f}$, so there is a pair $a \in (\frac{1}{f}\mathbf{Z}/\mathbf{Z})^2$ such that $1 = a_1\omega_1 + a_2\omega_2$. Define the *elliptic unit*

$$u(\sigma, \mathfrak{f}) = f_a(\tau) = g_a(\tau)^{12f}.$$

Theorem 3.27.

1. *The quantity $u(\sigma, \mathfrak{f})$ depends only on σ and not on our choice of \mathfrak{a} or on the subsequent choices of τ and a .*

2. If \mathfrak{f} has at least two distinct prime factors, then $u(\sigma, \mathfrak{f})$ is a unit in $\mathcal{O}_{K_{\mathfrak{f}}}$.

3. The Shimura reciprocity law holds:

$$u(\sigma, \mathfrak{f})^{\tau} = u(\sigma\tau, \mathfrak{f}) \quad (\sigma, \tau \in \text{Gal}(K_{\mathfrak{f}}/F)).$$

Thus, the Siegel functions allow us to construct units in ray class fields of imaginary quadratic fields; in fact, they are (up to a power) the Stark units. This fact follows from a formula of Kronecker that we will now describe. For $\omega = (\omega_1, \omega_2)$, τ , and z as above, and define

$$\begin{aligned} Z(z, \omega, s) &= \sum_{m,n} \mathbf{N}(z + m\omega_1 + n\omega_2)^{-s} \\ &= |\omega_1|^{-s} \sum_{m,n} \mathbf{N}(z/\omega_1 + m + n\tau)^{-s} \end{aligned}$$

Note that $Z(z, \omega, s)$ depends only on the coset $z + \mathbf{Z}\omega_1 + \mathbf{Z}\omega_2$, and that the $\mathbf{N}(z + m\omega_1 + n\omega_2)$ does not vanish for $m, n \in \mathbf{Z}$ so long as $z \notin \mathbf{Z}\omega_1 + \mathbf{Z}\omega_2$. In particular, every term in the above sum is well-defined if $z = x_1\omega_1 + x_2\omega_2$ and not both x_1 and x_2 are integral.

Theorem 3.28 (Kronecker's second limit formula). *Suppose a_1 and a_2 are not both integral. Then $Z(a_1\omega_1 + a_2\omega_2, \omega, s)$ vanishes at $s = 0$ and*

$$Z'(a_1\omega_1 + a_2\omega_2, \omega, s) = -\log |g_a(\tau)|^2. \quad (3.44)$$

Let σ, τ , and a be as above and let $w = |E(\mathfrak{f})|$. As $\mathbf{Z}\omega_1 + \mathbf{Z}\omega_2 + 1 = 1 + \mathfrak{a}^{-1}\mathfrak{f}$, we have

$$\mathbf{N}\mathfrak{a}^{-s} \cdot Z(1, \omega, s) = w\zeta_{K/F,S}(\sigma, s). \quad (3.45)$$

Corollary 3.29. *We have:*

$$\zeta'_{K/F,S}(\sigma, 0) = -\frac{1}{12fw} \log |f_a(\tau)|^2 = -\frac{1}{12fw} \log |u(\sigma, \mathfrak{f})|^2 \quad (3.46)$$

Stark proved in [32] that $u(\sigma, \mathfrak{f}) \in U_{v,S}$. In fact, he proved that the number e of roots of unity in K divides $12fw$, and that $u(\sigma, \mathfrak{f})$ is the $(12fw/e)$ -th power of an element $u(\sigma) \in U_{v,S}$. Furthermore, these roots are compatible in the sense that $u(\sigma) = u(1)^\sigma$. Finally, he proved that $u(\sigma)^{1/e} = g_a(\tau)^{1/w}$ generates an abelian extension of F . Combining these results with Corollary 3.29, Stark obtained a proof of his rank one abelian Conjecture 1.1 in the case of quadratic imaginary fields F .

Let us now use (3.44) as inspiration for how we may “get inside the absolute value” in the statement of Stark's conjecture. We view (3.44) as a decomposition of $Z'(a_1\omega_1 + a_2\omega_2, \omega, 0)$:

$$Z'(a_1\omega_1 + a_2\omega_2, \omega, 0) = -(\log g_a(\tau)_1 + \log g_a(\tau)_2) \quad (3.47)$$

into two components corresponding to the embeddings $x \mapsto x_i$, $i = 1, 2$, of F into \mathbf{C} . We have seen such decompositions already, namely (3.43) in the context of Shintani zeta functions. These phenomena are related: Note that we may write

$$\begin{aligned}
Z(z, \omega, s) &= \sum_{m \in \mathbf{Z}_{\geq 0}^2} N(z + m_1 \omega_1 + m_2 \omega_2)^{-s} \\
&+ \sum_{m \in \mathbf{Z}_{\geq 0}^2} N(z + (-1 - m_1) \omega_1 + m_2 \omega_2)^{-s} \\
&+ \sum_{m \in \mathbf{Z}_{\geq 0}^2} N(z + m_1 \omega_1 + (-1 - m_2) \omega_2)^{-s} \\
&+ \sum_{m \in \mathbf{Z}_{\geq 0}^2} N(z + (-1 - m_1) \omega_1 + (-1 - m_2) \omega_2)^{-s}. \tag{3.48}
\end{aligned}$$

Assume that $E(\mathfrak{f}) = \{1\}$. Then the above decomposition of $Z(z, \omega, s)$ corresponds to an expression of $Z(s, \omega, s)$ as a combination of Shintani zeta functions. By (3.48), $z \notin \mathbf{Z}\omega_1 + \mathbf{Z}\omega_2$ implies that

$$z + \mathbf{Z}\omega_1 + \mathbf{Z}\omega_2 = (z + \mathbf{Z}\omega_1 + \mathbf{Z}\omega_2) \cap \bigcup_{\sigma \in \{\pm\}^2} c_\sigma,$$

where

$$c_{++} = c(\omega_1, \omega_2), \quad c_{-+} = c(-\omega_1, \omega_2), \quad c_{--} = c(-\omega_1, -\omega_2), \quad c_{+-} = c(\omega_1, -\omega_2).$$

Let u_σ be a rotation matrix for c_σ and write a_σ for a_{c_σ} , $\sigma \in \{\pm\}^2$. Then

$$\begin{aligned}
Z(z, \omega, s) &= \sum_{\sigma \in \{\pm\}^2} \zeta \left(u_{++} a_{++}, \begin{pmatrix} x_1 \\ x_2 \end{pmatrix}, s \right) + \zeta \left(u_{-+} a_{-+}, \begin{pmatrix} 1 - x_1 \\ x_2 \end{pmatrix}, s \right) + \\
&\quad \zeta \left(u_{--} a_{--}, \begin{pmatrix} 1 - x_1 \\ 1 - x_2 \end{pmatrix}, s \right) + \zeta \left(u_{+-} a_{+-}, \begin{pmatrix} x_1 \\ 1 - x_2 \end{pmatrix}, s \right)
\end{aligned}$$

holds whenever $z \notin \mathbf{Z}\omega_1 + \mathbf{Z}\omega_2$. This holds in particular when $z = 1$ in which case, by (3.45), we have an expression for $\zeta_S(\sigma, s)$ as a sum of four Shintani zeta functions. By the following exercise, this is the decomposition of $\zeta_S(\sigma_{\mathfrak{a}}, s)$ subordinate to the Shintani fan

$$\mathcal{C} := \{c_\sigma : \sigma \in \{\pm\}^2\}.$$

Exercise 3.30.

1. We may assume without loss of generality that $0 \leq x_i \leq 1$, for $i = 1, 2$, with strict inequalities for at least one i . Why?
2. Show that

$$(1 + \mathbf{Z}\omega_1 + \mathbf{Z}\omega_2) \cap P_{c_{++}} = \left\{ \begin{pmatrix} x_1 \\ x_2 \end{pmatrix} \right\},$$

and similarly for the other cones in \mathcal{C} .

Thus, by (3.43), we have

$$\Phi_1(\mathfrak{a}, \mathcal{C}, \{u_c\}) + \Phi_2(\mathfrak{a}, \mathcal{C}, \{u_c\}) \equiv \zeta'_S(\sigma_{\mathfrak{a}}, 0) \pmod{\frac{2\pi i}{N}\mathbf{Z}}.$$

Note that $\Phi_1(\mathfrak{a}, \mathcal{C}, \{u_c\})$ and $\Phi_2(\mathfrak{a}, \mathcal{C}, \{u_c\})$ are complex conjugate and that, by statement 2. of Proposition 3.23, the cosets

$$\Phi_k(\mathfrak{a}, \mathcal{C}, \{u_c\}) + \frac{2\pi i}{Nw}\mathbf{Z} \quad (k = 1, 2)$$

are independent of \mathcal{C} . Let us denote these cosets by $\Phi_k(\mathfrak{a})$.

Theorem 3.31 ([28]). *Let f be the smallest positive integer in \mathfrak{f} . Then we may take $N = f$ and we have*

$$\Phi_k(\mathfrak{a}) \equiv -\log g_{\mathfrak{a}}(\tau)^{(k)} \pmod{\frac{2\pi i}{Nw}\mathbf{Z}}$$

Since the multiple Γ -functions constitute the main terms of derivatives at $s = 0$ of Shintani zeta functions, it becomes less surprising that Shintani's method can be used to prove the Kronecker limit formula. The standard construction of the Siegel function uses the theory of elliptic functions. The prototypical elliptic function, the Weierstrass \wp -function, is intimately related to the double gamma function.

Exercise 3.32. *Show that*

$$\frac{d^3}{dz^3}\Gamma(z, (\omega_1, \omega_2)) = -2 \sum_{m,n} (z + m\omega_1 + n\omega_2)^{-3} = \frac{d}{dz}\wp(z, (\omega_1, \omega_2)).$$

Can you compute the constant

$$\nu := \frac{d^2}{dz^2}\Gamma(z, (\omega_1, \omega_2)) - \wp(z, (\omega_1, \omega_2))?$$

3.9 Complex cubic fields—the work of Ren and Sczech

Let F be an ATR cubic field with distinct embeddings

$$x \mapsto x_1 \in \mathbf{R}, \quad x \mapsto x_2 \in \mathbf{C}, \quad x \mapsto x_3 \in \mathbf{C}.$$

Note that x_2 and x_3 are complex conjugates for all $x \in F$. Let \mathfrak{f} , σ , and \mathfrak{a} all be as in §3.6 and let ε be the generator of $E(\mathfrak{f})$ such that $\varepsilon_1 > 1$. Let $(\mathcal{C}, \{u_c\})$ be as Theorem 3.14. Define

$$\vartheta(\mathfrak{a}, \mathcal{C}) = \vartheta_2(\mathfrak{a}, \mathcal{C}) = \Phi_2(\mathfrak{a}, \mathcal{C}) - \Phi_1(\mathfrak{a}, \mathcal{C}) \frac{\log \varepsilon_2}{\log \varepsilon_1}.$$

Proposition 3.33.

1. *The coset $\vartheta(\mathfrak{a}, \mathcal{C}) + \frac{2\pi i}{N}\mathbf{Z}$ does not depend on our choices of \mathfrak{a} and \mathcal{C} .*

2. We have

$$\vartheta(\mathbf{a}, \mathcal{C}) + \overline{\vartheta(\mathbf{a}, \mathcal{C})} = \Phi_1(\mathbf{a}, \mathcal{C}) + \Phi_2(\mathbf{a}, \mathcal{C}) + \Phi_3(\mathbf{a}, \mathcal{C}) = \zeta'_S(\sigma, 0).$$

Proof. We first consider the dependence on \mathcal{C} . Let \mathcal{C}' be another Shintani fan for F . By Proposition 3.23, there is a unit $\eta \in E(\mathfrak{f})$ such that

$$\Phi_k(\mathbf{a}, \mathcal{C}') - \Phi_k(\mathbf{a}, \mathcal{C}) \equiv \frac{1}{N} \log \eta_1 \pmod{\frac{2\pi i}{N} \mathbf{Z}} \quad (k = 1, 2, 3). \quad (*_k)$$

Multiplying $*_1$ by $\log(\eta_2)/\log(\eta_1)$ and subtracting the result from $*_2$, we obtain

$$\Phi_2(\mathbf{a}, \mathcal{C}') - \frac{\log \eta_2}{\log \eta_1} \Phi_1(\mathbf{a}, \mathcal{C}') \equiv \Phi_2(\mathbf{a}, \mathcal{C}) - \frac{\log \eta_2}{\log \eta_1} \Phi_1(\mathbf{a}, \mathcal{C}) \pmod{\frac{2\pi i}{N} \mathbf{Z}}.$$

Since ε generates $E(\mathfrak{f})$, $\eta = \varepsilon^m$ for some $m \in \mathbf{Z}$ and we have

$$\frac{\log(\eta_2)}{\log(\eta_1)} = \frac{\log(\varepsilon_2)}{\log(\varepsilon_1)}.$$

(This is where we use the fact that we are working with a cubic field.) Therefore, 1. holds. We now prove 2. Since $\Phi_1(\mathbf{a}, \mathcal{C})$ is real and $\overline{\Phi_2(\mathbf{a}, \mathcal{C})} = \Phi_3(\mathbf{a}, \mathcal{C})$,

$$\begin{aligned} \vartheta(\mathbf{a}, \mathcal{C}) + \overline{\vartheta(\mathbf{a}, \mathcal{C})} &= -\Phi_1(\mathbf{a}, \mathcal{C}) \frac{\log \varepsilon^{(2)} + \log \varepsilon^{(3)}}{\log \varepsilon^{(1)}} + \Phi_2(\mathbf{a}, \mathcal{C}) + \Phi_3(\mathbf{a}, \mathcal{C}) \\ &= \Phi_2(\mathbf{a}, \mathcal{C}) - \frac{\log(\varepsilon_2)}{\log(\varepsilon_1)} \Phi_1(\mathbf{a}, \mathcal{C}) + \Phi_3(\mathbf{a}, \mathcal{C}) - \frac{\log(\varepsilon_3)}{\log(\varepsilon_1)} \Phi_1(\mathbf{a}, \mathcal{C}) \\ &= \Phi_1(\mathbf{a}, \mathcal{C}) + \Phi_2(\mathbf{a}, \mathcal{C}) + \Phi_3(\mathbf{a}, \mathcal{C}) \\ &= \zeta'_{K/F,S}(\sigma_{\mathbf{a}}, 0), \end{aligned}$$

where the penultimate equality uses the fact that $\log \varepsilon^{(1)} + \log \varepsilon^{(2)} + \log \varepsilon^{(3)} = 0$. \square

Therefore, the following is compatible with Stark's conjecture:

Conjecture 3.34 ([20, Conjecture 2]). *The Stark unit $u(\sigma, \mathfrak{f})$ satisfies*

$$\log u(\sigma, \mathfrak{f})_2 \equiv \vartheta_2(\mathbf{a}, \mathcal{C}) \pmod{\frac{2\pi i}{N} \mathbf{Z}} \quad (k = 2, 3).$$

Since complex cubic fields have unit rank one, the quotient $\eta_{k'}/\eta_k$ is independent of η for any k, k' . We used this fact in an essential way in the proof of Proposition 3.33.

Question: Can the methods described above be adapted to give candidate formulas for Stark units of ATR fields of degree > 3 ?

3.10 TR_∞ – The invariants of Shintani and Yamamoto

Let F be a totally real field with infinite places v_1, \dots, v_m . For $x \in F$, we abbreviate $v_i(x)$ by $x^{(i)}$. Let \mathfrak{f} be an ideal of \mathcal{O}_F , let $K_{\mathfrak{f}}$ be the narrow ray class field of F of conductor \mathfrak{f} , and let $G(\mathfrak{f}) = \text{Gal}(K_{\mathfrak{f}}/F)$. Choose elements $\mu_1, \dots, \mu_m \in \mathcal{O}_F$ such that

$$\mu_i^{(j)} \begin{cases} < 0 & \text{if } i = j; \\ > 0 & \text{if } i \neq j, \end{cases} \quad (3.49)$$

and let $\tau_i \in G(\mathfrak{f})$ be the image of (μ_i) under the Artin map. Let χ be a character of $G(\mathfrak{f})$ and consider the Hecke L -function $L(\chi, s)$. Then

$$\text{ord}_{s=0} L(\chi, s) = |\{i : \chi(\tau_i) = 1\}|. \quad (3.50)$$

Let $\mu = \mu_1 \cdots \mu_m$ and $\tau = \tau_1 \cdots \tau_m$, and define

$$\zeta^+(\sigma, s) = -\zeta(\sigma, s) + (-1)^m \zeta(\sigma\tau, s).$$

Lemma 3.35. *We have $\zeta^+(\sigma, 0) = 0$ for all $\sigma \in G(\mathfrak{f})$.*

Proof. Applying the Fourier inversion formula,

$$\zeta(\sigma\tau, 0) = \sum_{\chi: G(\mathfrak{f}) \rightarrow \mathbf{C}^\times} \chi(\sigma\tau)^{-1} L(\chi, 0).$$

By (3.50), $L(\chi, 0) = 0$ unless $\chi(\tau_i) = -1$ for all i , in which case $\chi(\tau) = (-1)^m$. Therefore,

$$\zeta(\sigma\tau, 0) = (-1)^m \zeta(\sigma, 0).$$

The result follows. □

Since $\zeta^+(\sigma, s)$ vanishes at $s = 0$, it is natural to investigate the derivative. Define the *Shintani-Yamamoto invariant* by

$$X(\sigma) = \exp \left(\left. \frac{d}{ds} \right|_{s=0} \zeta^+(\sigma, s) \right).$$

This invariant was introduced by Shintani in the case $m = 2$. Its definition and properties in the case of totally real fields of arbitrary degree are due to Yamamoto. To connect $X(\sigma)$ with the Stark conjecture for Hecke L -functions, fix an index i and let $\chi : G(\mathfrak{f}) \rightarrow \mathbf{C}^\times$ be such that

$$\chi(\tau_j) = \begin{cases} 1 & \text{if } i = j; \\ -1 & \text{if } i \neq j. \end{cases}$$

Then $L(\chi, s)$ has a simple zero at $s = 0$, putting us in case TR_∞ .

Proposition 3.36. *We have:*

$$L(\chi, s) = -\frac{1}{2} \sum_{\sigma \in G(\mathfrak{f})} \chi(\sigma) X(\sigma).$$

Proof. Choose a set of representatives $\{\varrho\}$ for $G(\mathfrak{f})/\langle\tau\rangle$. Then

$$\begin{aligned} L(\chi, 0) &= \sum_{\varrho} (\chi(\varrho)\zeta(\varrho, 0) + \chi(\varrho\tau)\zeta(\varrho\tau, 0)) \\ &= \sum_{\varrho} \chi(\varrho) (\zeta(\varrho, 0) + (-1)^{m-1}\zeta(\varrho\tau, 0)) \\ &= -\frac{1}{2} \sum_{\sigma \in G(\mathfrak{f})} \chi(\sigma) X(\sigma) \quad \square \end{aligned}$$

Let \mathfrak{a} be an ideal, $(\mathfrak{a}, \mathfrak{f}) = 1$, whose image under the Artin map is $\sigma \in G(\mathfrak{f})$. Let \mathcal{A} be the set of constituent cones of a Shintani fundamental domain of $E(\mathfrak{f})$ acting on $\mathbf{R}_{>0}^m$ such that, for every $A \in \mathcal{A}$, we have $A^{(j)} \in \mathfrak{a}^{-1}\mathfrak{f}$ for all j . Define the *refined Shintani-Yamamoto invariant*

$$X_k(\sigma) = \prod_{A \in \mathcal{A}} \prod_{x \in \Omega(1, \mathfrak{a}^{-1}\mathfrak{f}, A)} \mathcal{S}(x^{(k)}, A^{(k)}).$$

Theorem 3.37 (Shintani ($m = 2$), Yamamoto ($m \geq 2$)). *The invariant $X_k(\sigma)$ is well defined, i.e., its value does not depend on our choice of ideal \mathfrak{a} or cone decomposition \mathcal{A} . Moreover, we have the following decomposition of $X(\sigma)$*

$$X(\sigma) = \prod_{k=1}^m X_k(\sigma).$$

Remark 3.38. The quantities $\log X(\sigma)$ and $\log (X_1(\sigma) \cdots X_m(\sigma))$ are the derivatives at $s = 0$ of the partial zeta function $\zeta^+(\sigma, s)$ and the Shintani zeta function $\zeta^+(\mathfrak{a}, \mathcal{A}, s)$, respectively. The main step in the proof of the theorem is establishing the equality of these two zeta functions.

The following result indicates that the construction of the refined Shintani-Yamamoto invariants is consistent with a hypothetical Shimura reciprocity law:

Theorem 3.39 (Shintani ($m = 2$), Yamamoto ($m \geq 2$)). *We have:*

$$X_k(\tau_j \sigma) = \begin{cases} X_k(\sigma) & \text{if } j = k; \\ X_k(\sigma)^{-1} & \text{if } j \neq k. \end{cases}$$

From here, a formal argument establishes the following sharpening of Proposition 3.36.

Corollary 3.40. *Let χ be as in Proposition 3.36. Then*

$$L(\chi, s) = -\frac{1}{2} \sum_{\sigma \in G(\mathfrak{f})} \chi(\sigma) X_i(\sigma).$$

Exercise 3.41. *Prove the corollary. Hint: Consider the sum*

$$\sum_{\nu \in \{0,1\}^m} \chi(\tau_1^{\nu_1} \cdots \tau_m^{\nu_m} \sigma) \log X(\tau_1^{\nu_1} \cdots \tau_m^{\nu_m} \sigma).$$

Chapter 4

Eisenstein cocycles and applications to case TR_p

4.1 Motivation: Siegel's formula

The definition of the Eisenstein cocycle is motivated by a formula of Siegel relating special values of zeta functions of real quadratic fields to periods of Eisenstein series.

4.1.1 Eisenstein series

For an even integer $k > 2$, consider the weight k Eisenstein series defined by the absolutely convergent sum:

$$E_k(z) := \sum'_{m,n} \frac{1}{(mz+n)^k} \quad (4.1)$$

$$= \frac{2(2\pi i)^k}{(k-1)!} \left[-\frac{B_k}{2k} + \sum_{n=1}^{\infty} \sum_{d|n} d^{k-1} q^n \right]. \quad (4.2)$$

As usual, the ' adorning the sum in (4.1) indicates that the sum runs over all pairs

$$(m, n) \in \mathbf{Z}^2 - \{(0, 0)\}.$$

The Bernoulli numbers B_k appearing in (4.2) are defined for all $k \geq 0$ by the formal power series

$$\frac{te^{xt}}{e^t - 1} = \sum_{n=0}^{\infty} B_n(x) \frac{t^n}{n!},$$

with $B_k = B_k(0)$. The holomorphic function E_k on the upper half plane \mathcal{H} is a modular form of weight k for $\Gamma := \mathbf{SL}_2(\mathbf{Z})$.

More generally, fix a pair $v = (v_1, v_2) \in (\mathbf{Q}/\mathbf{Z})^2$ and define

$$E_{k,v}(z) := \sum'_{m,n} \frac{e(mv_1 + nv_2)}{(mz+n)^k}, \quad e(x) := e^{2\pi i x}. \quad (4.3)$$

If we write $(v_1, v_2) = (a/N, b/N)$, the q -expansion of $E_{k,(v_1,v_2)}$ is given by

$$E_{k,(v_1,v_2)}(z) = \frac{2(2\pi i)^k}{(k-1)!} \left[-\frac{\tilde{B}_k(v_2)}{2k} + \frac{1}{N^{k-1}} \sum_{n=1}^{\infty} \sigma_{k-1,(v_1,v_2)}(n) q_N^n \right], \quad q_N = e(z/N), \quad (4.4)$$

where

$$\sigma_{k-1,(v_1,v_2)}(n) = \frac{1}{2} \left(\sum_{\substack{d|n \\ d \equiv b \pmod{N}}} d^{k-1} e\left(-\frac{n}{d}v_1\right) + (-1)^k \sum_{\substack{d|n \\ d \equiv -b \pmod{N}}} d^{k-1} e\left(\frac{n}{d}v_1\right) \right).$$

Here the ‘‘periodic Bernoulli polynomials’’ $\tilde{B}_k(x)$ are defined by $\tilde{B}_k(x) = B_k(x - [x])$ if $k \neq 1$, and

$$\tilde{B}_1(x) = \begin{cases} x - [x] - \frac{1}{2} & x \notin \mathbf{Z} \\ 0 & x \in \mathbf{Z}. \end{cases} \quad (4.5)$$

For $k \geq 1$, these periodic functions satisfy the explicit Fourier expansion:

$$\tilde{B}_k(x) = -\frac{k!}{(2\pi i)^k} \sum'_{n \in \mathbf{Z}} \frac{e(nx)}{n^k}. \quad (4.6)$$

The sum (4.6) converges absolutely for $k > 1$, but requires special comment for $k = 1$. One can evaluate the sum either by summing from $-N$ to N and taking the limit as $N \rightarrow \infty$ (‘‘Eisenstein summation’’) or by introducing a factor of $|n|^s$ in the denominator, which causes the sum to converge absolutely for $\operatorname{Re}(s) > 0$, and taking the limit as $s \rightarrow 0$ from the right (‘‘Hecke summation’’). It turns out that both methods give the same result (this follows from Abel’s Theorem for Dirichlet Series, see [25]), namely the function (4.5).

In view of the absolute convergence of the sum defining $E_{k,v}(z)$ for $k > 2$, it is easy to see that $E_{k,v}$ is a modular form of weight k for the modular group $\Gamma(N) \subset \Gamma$, where N is the denominator of v . More generally, the $E_{k,v}$ for varying v are permuted under the weight k action of Γ ; for $\gamma = \begin{pmatrix} a & b \\ c & d \end{pmatrix} \in \Gamma$, we have

$$E_{k,v}|_{\gamma}(z) = (cz + d)^{-k} E_{k,v}(\gamma z) = E_{k,\gamma^{-1}v}(z), \quad (4.7)$$

where Γ acts on \mathbf{Q}^2 by left multiplication on column vectors.

Because the series (4.3) does not converge absolutely for $k = 2$, the situation for the Eisenstein series of weight 2 is somewhat more delicate. Hecke’s method of dealing with the problem is to introduce an extra complex variable s :

$$E_{2,v}(z, s) := \sum'_{m,n} \frac{e(mv_1 + nv_2)}{(mz + n)^2 |mz + n|^s}.$$

This sum converges absolutely for $\operatorname{Re}(s) > 0$, and for fixed z can be extended by analytic continuation to a function of s on the entire complex plane. Hecke then considered the value of the analytically continued $E_{2,v}(z, s)$ at $s = 0$.

A more classical way to deal with the weight 2 Eisenstein series, due to Eisenstein, is to specify an order of summation for the terms in the conditionally convergent sum. We may define:

$$E_{2,v}(z) := \lim_{M \rightarrow \infty} \sum_{m=-M}^M \left(\lim_{N \rightarrow \infty} \sum'_{n=-N}^N \frac{e(mv_1 + nv_2)}{(mz + n)^2} \right).$$

The Eisenstein summation method yields the function $E_{2,v}(z)$ with q -expansion given by (4.4). A proof of this fact is given in [34, Part III, equation (11)]. The Hecke summation yields the same function $E_{2,v}(z)$ when $v \neq (0, 0) \in (\mathbf{Q}/\mathbf{Z})^2$. However, when $v = 0$, the Hecke summation method yields the function

$$E_{2,(0,0)}(z, 0) = E_{2,(0,0)}(z) + \frac{\pi}{\operatorname{Im}(z)}.$$

The holomorphic function $E_2(z) = E_{2,(0,0)}$ on the upper half-plane obtained using Eisenstein summation is *not* a modular form of weight 2; it satisfies a transformation formula for the weight 2 action of Γ that contains a certain “error term.” Conversely, the function $E_2(z) + \pi/\operatorname{Im}(z)$ obtained using Hecke summation is invariant under the weight 2 action of Γ , but it is not holomorphic.

We avoid these difficulties by only considering¹

$$v \in \mathcal{V} := (\mathbf{Q}/\mathbf{Z})^2 - \{(0, 0)\},$$

for which the function $E_{2,v}(z)$ is in fact a modular form of weight 2 for the group $\Gamma(N)$, where N is the denominator of v . This fact can be proven using the fact that $E_{2,v}$ can be expressed as a linear combination of certain special values of the Weierstrass \wp -function.² Alternatively, one can show that for $v \in \mathcal{V}$, $E_{2,v}(z)$ is a scalar multiple of the logarithmic derivative of a modular unit on $\Gamma(N)$ called a Siegel unit. (Recall that a modular unit is a modular function of weight zero with no zeroes or poles on \mathcal{H} ; the logarithmic derivative of such a function is always a modular form of weight 2.) Furthermore, the $E_{2,v}$ satisfy (4.7) for $v \in \mathcal{V}$.

¹We view the elements of \mathcal{V} as column vectors, so \mathcal{V} has a natural left Γ -action.

²Exercise: Prove that if $(a, b) \notin N\mathbf{Z}^2$, then

$$E_{2,(a/N, b/N)}(z) = \frac{1}{N^2} \sum_{\substack{A, B=0 \\ (A, B) \neq (0, 0)}}^{N-1} e\left(\frac{Aa + Bb}{N}\right) \wp_z\left(\frac{Az + B}{N}\right), \quad (4.8)$$

where \wp_z denotes the Weierstrass function associated to the lattice $\langle 1, z \rangle$:

$$\wp_z(x) = \frac{1}{x^2} + \sum'_{m, n \in \mathbf{Z}} \left(\frac{1}{(mz + n + x)^2} - \frac{1}{(mz + n)^2} \right),$$

using the final formula of [34, Chapter III, §8]. Conclude that $E_{2,(a/N, b/N)}(z)$ is a modular form of weight 2 on $\Gamma(N)$.

Finally, we note a distribution property satisfied by the $E_{k,v}(z)$. For each positive integer N and fixed $v \in (\mathbf{Q}/\mathbf{Z})^2$, assuming additionally that $v \in \mathcal{V}$ if $k = 2$, we have

$$\sum_{w \in (\frac{1}{N}\mathbf{Z}/\mathbf{Z})^2} E_{k,v/N+w}(z) = N^{2-k} \cdot E_{k,v}(z). \quad (4.9)$$

4.1.2 The Dedekind-Rademacher homomorphism

Though not essential for our exposition, we would be remiss if we did not mention the *Dedekind-Rademacher homomorphism*. Fix a prime $p \in \mathbf{Z}$. The congruence subgroup

$$\Gamma_0(p) \subset \Gamma = \mathbf{SL}_2(\mathbf{Z})$$

is the subgroup of matrices whose reductions modulo p are upper triangular. Define

$$\begin{aligned} E_2^*(z) &:= E_2(z) - pE_2(pz) \\ &= 2(2\pi i)^2 \left[\frac{p-1}{24} + \sum_{n=1}^{\infty} \sum_{\substack{d|n \\ (d,p)=1}} dq^n \right]. \end{aligned} \quad (4.10)$$

The fact that $E_2^*(z)$ is a modular form of weight 2 on $\Gamma_0(p)$ follows from the transformation property of $E_2(z)$ under the action of Γ (the “error terms” for $E_2(z)$ and $pE_2(pz)$ cancel). However, we give another proof that perhaps sheds more light on the situation. Associated to the prime p we define the modular unit $\alpha(z) := \Delta(pz)/\Delta(z)$ on $\Gamma_0(p) \setminus \mathcal{H}$ (recall that a modular function is called a modular unit if it has no zeroes or poles on the complex upper half plane). It is easy to check using the q -expansion of Δ that the logarithmic derivative of α is simply $E_2^*(z)$, up to a constant:

$$E_2^*(z) = \frac{2\pi i}{12} \cdot \frac{\alpha'(z)}{\alpha(z)}. \quad (4.11)$$

Exercise: prove (4.11) by comparing q -expansions and conclude that $E_2^*(z)$ is a modular form of weight 2 on $\Gamma_0(p)$.

The modular form $E_2^*(z)$ defines a homomorphism $\Phi_p : \Gamma_0(p) \rightarrow \mathbf{Z}$ by the rule

$$\Phi_p(\gamma) = \frac{12}{(2\pi i)^2} \int_{\tau}^{\gamma\tau} E_2^*(z) dz, \quad (4.12)$$

for any $\tau \in \mathcal{H}$. The fact that $E_2^*(z) dz$ is invariant under γ implies that the value (4.12) is independent of τ . The fact that Φ_p is an integer follows from equation (4.11) and the argument principle: let c denote a smooth oriented path in the upper half-plane connecting the point τ to $\gamma\tau$; then $\Phi_p(\gamma)$ is the winding number of the closed path $\alpha(c)$ around the origin in the complex plane. The homomorphism Φ_p is called the Dedekind–Rademacher homomorphism, and is studied in detail in [19].

Note that the forms $E_{2,v}$ refine E_2^* in the sense that

$$\sum_{i=1}^{p-1} E_{2,(i/p,0)}(z) = -E_2^*(z).$$

4.1.3 Siegel's formula

Let F be a real quadratic field, and let \mathfrak{f} be an ideal of \mathcal{O}_F . Define $K = K_{\mathfrak{f}}$ to be the narrow ray class field of F associated to the conductor \mathfrak{f} , and let R denote the set of archimedean primes and those dividing \mathfrak{f} . Let \mathfrak{a} be an ideal of \mathcal{O}_F relatively prime to \mathfrak{f} , and denote by $\sigma_{\mathfrak{a}}$ the Frobenius automorphism in $G = \text{Gal}(K/F)$ associated to \mathfrak{a} . Siegel's formula expresses the values of the ζ -function $\zeta_{K/F,R}(\sigma_{\mathfrak{a}}, s)$ at nonpositive integers as periods of Eisenstein series.

Fix a \mathbf{Z} -basis $\{w_1, w_2\}$ for the fractional ideal $\mathfrak{a}^{-1}\mathfrak{f}$. Fix a real place of F and assume that the basis is oriented in the sense that

$$w_1\bar{w}_2 - w_2\bar{w}_1 > 0 \quad (4.13)$$

at this place. The pair $\{w_1, w_2\}$ provides a \mathbf{Q} basis for F , and the action of multiplication by F on itself provides an embedding

$$\iota : F \hookrightarrow M_2(\mathbf{Q}) \text{ such that } \iota(\mathcal{O}_F) \subset M_2(\mathbf{Z});$$

explicitly we have

$$\iota(\alpha) = \begin{pmatrix} a & b \\ c & d \end{pmatrix} \quad \text{where} \quad (w_1\alpha, w_2\alpha) = (w_1, w_2) \begin{pmatrix} a & b \\ c & d \end{pmatrix}. \quad (4.14)$$

Let ε denote a fundamental totally positive unit of F congruent to 1 (mod \mathfrak{f}) such that

$$0 < \varepsilon < 1 \quad (4.15)$$

in our chosen real embedding. Let

$$\gamma = \iota(\varepsilon) \in \Gamma. \quad (4.16)$$

Let $\mathcal{P} = \mathbf{Q}[x, y]$, and let Γ act on \mathcal{P} by³

$$(gP)(x, y) := P((x, y)g).$$

Define a quadratic form $P \in \mathcal{P}$:

$$\begin{aligned} P(x, y) &= \mathbf{N}\mathfrak{a} \cdot \text{Norm}_{F/\mathbf{Q}}(xw_1 + yw_2) \\ &= \mathbf{N}\mathfrak{a} \cdot (xw_1 + yw_2)(x\bar{w}_1 + y\bar{w}_2) \in \mathbf{Z}[x, y]. \end{aligned} \quad (4.17)$$

While the quadratic form P depends on the chosen basis w_1, w_2 , the Γ -equivalence class of P depends only on the ideal $\mathfrak{a}^{-1}\mathfrak{f}$ (and the fixed real place used to define the orientation). Next, define a vector $v = (v_1, v_2) \in \mathbf{Q}^2$ by the equation

$$1 = v_1w_1 + v_2w_2. \quad (4.18)$$

Siegel's formula may be stated:

³Our convention is that the argument of P is a row vector. However, we will often be interested in the value of P on a column vector v , in which case we simply write $P(v)$ for $P(v^t)$, where v^t is the transpose of v . In terms of the action of Γ , we have $(gP)(v) := (gP)(v^t) = P(v^t g)$, which is written in terms of a column vector as $P(g^t v)$. This should not cause confusion, because only one of the expressions gv or vg makes sense if v is a vector, depending on whether it is a column vector or row vector.

Theorem 4.1. Fix τ in the complex upper half-plane \mathcal{H} . Let $r \geq 1$ be an integer, and suppose that $v \in \mathcal{V}$ when $r = 1$. Then

$$\zeta_{K/F,R}(\sigma_{\mathfrak{a}}, 1 - r) = \frac{(2r - 1)!}{(2\pi i)^{2r}} \int_{\tau}^{\gamma\tau} P(z, 1)^{r-1} E_{2r,v}(z) dz. \quad (4.19)$$

Exercise: prove that

$$\gamma^t P = P \quad \text{and} \quad \gamma^{-1}v \equiv v \pmod{\mathbf{Z}^2},$$

and deduce that the right side of (4.19) is independent of τ . Prove furthermore that this value depends on the image of \mathfrak{a} in the narrow ray class group of conductor \mathfrak{f} , and not on \mathfrak{a} itself.

Proof. Siegel's theorem actually relates the right side of (4.19) to the value of a certain zeta function at r ; our formulation invokes the functional equation for these zeta functions. We will demonstrate how to obtain our result from Siegel's.

Consider the dual of the ideal $\mathfrak{a}^{-1}\mathfrak{f}$ under the trace map, namely $\mathfrak{a}\mathfrak{f}^{-1}\mathfrak{d}^{-1}$, where \mathfrak{d} is the different of F . This fractional ideal has \mathbf{Z} -basis $\{w_1^*, w_2^*\}$, the dual basis to the basis $\{w_1, w_2\}$ of $\mathfrak{a}^{-1}\mathfrak{f}$ under the trace. Note that this basis is oriented as in (4.13). Define

$$P^*(x, y) := N(\mathfrak{a}^{-1}\mathfrak{f}\mathfrak{d}) N(xw_1^* + yw_2^*) \in \mathbf{Z}[x, y]. \quad (4.20)$$

One may verify that $P^*(y, -x) \cdot N\mathfrak{f} = -P(x, y)$. Let γ^* denote the inverse transpose of γ . This matrix satisfies

$$(w_1^*, w_2^*)\gamma^* = (w_1^*, w_2^*)\varepsilon^{-1}.$$

Let us now invoke the change of variables

$$u = -1/z = S(z), \quad S = \begin{pmatrix} 0 & -1 \\ 1 & 0 \end{pmatrix},$$

in the integral on the right side of (4.19). Writing $\tau' = S\tau$, and noting $S\gamma^*S^{-1} = -\gamma$ we find

$$\begin{aligned} \int_{\tau}^{\gamma\tau} P(z, 1)^{r-1} E_{2r,v}(z) dz &= \int_{\tau'}^{\gamma^*\tau'} P(1, -u)^{r-1} E_{2r,(v_2,-v_1)}(u) du \\ &= (-N\mathfrak{f})^{r-1} \int_{\tau'}^{\gamma^*\tau'} P^*(u, 1)^{r-1} E_{2r,(v_2,-v_1)}(u) du. \end{aligned} \quad (4.21)$$

Hilfssatz 1 of [29] states that for $r > 1$, we have:

$$\int_{\tau}^{\gamma^*\tau} P^*(z, 1)^{r-1} E_{2r,(v_2,-v_1)}(z) dz = c_r \zeta(P^*, \gamma^*, v, r) \quad (4.22)$$

where

$$c_r = (-1)^{r-1} \frac{((r-1)!)^2}{(2r-1)!} D^{r-1/2}, \quad D = \text{disc}(F),$$

and

$$\zeta(P^*, \gamma^*, v, r) := \sum'_{(m,n)/\sim} \frac{e(mv_1 + nv_2)}{P^*(m, n)^r}. \quad (4.23)$$

Here the equivalence relation \sim on $\mathbf{Z}^2 - \{0\}$ is given by $(m, n) \sim (m, n)(\gamma^*)^t = (m, n)\gamma^{-1}$. Note that the sign denoted j in [29, Hilfssatz 1] is $+1$ since $\{w_1^*, w_2^*\}$ is oriented, and γ^* represents the action of $\varepsilon^{-1} > 1$ with respect to this basis.

The sum in (4.23) converges absolutely for $r > 1$, and we define it for $r = 1$ using Hecke summation; to be precise, we let

$$\zeta(P^*, \gamma^*, v, 1, s) := \sum'_{(m,n)/\sim} \frac{e(mv_1 + nv_2)}{P^*(m, n)|P^*(m, n)|^s}, \quad \operatorname{Re}(s) > 0, \quad (4.24)$$

and define

$$\zeta(P^*, \gamma^*, v, 1) := \lim_{s \rightarrow 0^+} \zeta(P^*, \gamma^*, v, 1, s). \quad (4.25)$$

The fact that (4.22) holds for $r = 1$ when $v \in \mathcal{V}$ is a form of Meyer's Theorem.

The value $\zeta(P^*, \gamma^*, v, r)$ is in fact the special value of a Hecke L -function of F as follows. Define two characters $\chi_i: F^* \rightarrow \{\pm 1\}$ by $\chi_0(x) = 1$, $\chi_1(x) = \operatorname{sign}(Nx)$. Define the associated L -functions

$$L_j^*(s) := \sum_{\alpha \in \mathfrak{a}\mathfrak{f}^{-1}\mathfrak{d}^{-1/\varepsilon}} \chi_j(\alpha) \frac{e(\operatorname{trace}(\alpha))}{|\mathbf{N}(\alpha)|^s}.$$

The function $L_j^*(s)$ converges for $\operatorname{Re}(s) > 1$ and has an analytic continuation to the entire complex plane. Under the change of variables $(m, n) \mapsto \alpha = mw_1^* + nw_2^*$, it is clear that

$$\zeta(P^*, \gamma^*, v, r) = \mathbf{N}(\mathfrak{a}^{-1}\mathfrak{f}\mathfrak{d})^{-r} L_j^*(r), \quad j \equiv r \pmod{2}. \quad (4.26)$$

The function $L_j^*(s)$ satisfies a functional equation relating it to

$$L_j(s) := \sum_{\alpha \in \mathfrak{a}^{-1}\mathfrak{f}+1/\varepsilon} \frac{\chi_j(s)}{|\mathbf{N}\alpha|^s},$$

namely,

$$L_j^*(s) = \frac{(-1)^j D^{1/2} (\mathbf{N}\mathfrak{a}^{-1}\mathfrak{f}) \pi^{2s} 2^{2s-2}}{\Gamma(s)^2} \cdot L_j(1-s). \quad (4.27)$$

This is [24, pg. 594]. Finally, one may show (see [24, pg. 595]) that

$$\zeta_{K/F,R}(\sigma_{\mathfrak{a}}, 1-r) = 2^{-2} \mathbf{N}\mathfrak{a}^{r-1} L_j(1-r). \quad (4.28)$$

Combining equations (4.21)–(4.22) and (4.26)–(4.28) gives the desired result (4.19). \square

4.1.4 The Eisenstein cocycle

Siegel’s formula expresses the partial zeta functions of all real quadratic fields via the same mechanism—integrate Eisenstein series against polynomials. It is then natural to consider more generally, for $\tau \in \mathcal{H}$ and $\gamma \in \Gamma$, the function $\mathcal{P} \times \mathcal{V} \rightarrow \mathbf{C}$ defined by

$$\Psi_\tau(\gamma)(P, v) := \frac{(d+1)!}{(2\pi i)^{d+2}} \int_\tau^{\gamma\tau} P(z, 1) E_{d+2, v}(z) dz \quad (4.29)$$

when P is a homogeneous polynomial of degree d , and extended by linearity to \mathcal{P} . Let \mathcal{M} denote the set of maps

$$f : \mathcal{P} \times \mathcal{V} \rightarrow \mathbf{C}$$

such that for fixed homogeneous $P \in \mathcal{P}$ of degree d the function

$$f(P, -) : \mathcal{V} \rightarrow \mathbf{C}$$

satisfies the distribution property

$$\sum_{w \in (\frac{1}{N}\mathbf{Z}/\mathbf{Z})^2} f\left(P, \frac{v}{N} + w\right) = N^{-d} \cdot f(P, v), \quad (4.30)$$

and for each fixed $v \in \mathcal{V}$, the function

$$f(-, v) : \mathcal{P} \rightarrow \mathbf{C}$$

is a \mathbf{Q} -linear map. It is easy to verify using the distribution property (4.9) of the $E_{k, v}$ that the function $\Psi_\tau(\gamma)$ is an element of \mathcal{M} .

The abelian group \mathcal{M} has a Γ -module structure given by

$$(\gamma f)(P, v) = f(\gamma^t P, \gamma^{-1} v).$$

Proposition 4.2. *The function $\Psi_\tau : \Gamma \rightarrow \mathcal{M}$ is an inhomogeneous 1-cocycle:*

$$\Psi_\tau(AB) = \Psi_\tau(A) + A\Psi_\tau(B) \quad (4.31)$$

for $A, B \in \Gamma$.

Proof. For a homogeneous polynomial P of degree d we calculate, writing

$$a_d = \frac{(d+1)!}{(2\pi i)^{d+2}}$$

for simplicity:

$$\begin{aligned} \Psi_\tau(AB)(P, v) &= a_d \int_\tau^{AB\tau} P(z, 1) E_{d+2, v}(z) dz \\ &= a_d \left[\int_\tau^{A\tau} P(z, 1) E_{k, v}(z) dz + \int_{A\tau}^{AB\tau} P(z, 1) E_{k, v}(z) dz \right] \\ &= a_d \left[\int_\tau^{A\tau} P(z, 1) E_{k, v}(z) dz + \int_\tau^{B\tau} P((z, 1)A^t) E_{k, A^{-1}v}(z) dz \right] \\ &= \Psi_\tau(A)(v) + \Psi_\tau(B)(A^t P, A^{-1}v) \\ &= (\Psi_\tau(A) + A\Psi_\tau(B))(P, v) \end{aligned}$$

as desired. □

We leave as an exercise the fact that the cohomology class $[\Psi_\tau] \in H^1(\Gamma, \mathcal{M})$ represented by Ψ_τ is independent of τ .

4.1.5 Pairing between cohomology and homology

Given that Ψ_τ is a cocycle whose cohomology class does not depend on τ , it is natural to state Siegel's formula in terms of the canonical pairing between the cohomology group $H^1(\Gamma, \mathcal{M})$ and the homology group $H_1(\Gamma, \mathcal{M}^\vee)$. Here $\mathcal{M}^\vee = \text{Hom}(\mathcal{M}, \mathbf{C})$ is the \mathbf{C} -vector space dual of \mathcal{M} , which is endowed with a natural dual Γ -action: $(\gamma m^\vee)(m) = m^\vee(\gamma^{-1}m)$.

For a Γ -module M , our notation for describing elements of $H_1(\Gamma, M)$ is as follows. Let I_Γ be the augmentation ideal of $\mathbf{Z}[\Gamma]$, which is endowed with a natural left Γ -action. The group $H_1(\Gamma, M)$ is identified with the kernel of the map

$$(I_\Gamma \otimes M)_\Gamma \longrightarrow (\mathbf{Z}[\Gamma] \otimes M)_\Gamma \cong M \quad (4.32)$$

The left side of (4.32) denotes the Γ -coinvariants of the tensor product $I_\Gamma \otimes M$, on which Γ acts componentwise.⁴ An element of $I_\Gamma \otimes M$ will be called a *1-chain*. A 1-chain whose image in $(I_\Gamma \otimes M)_\Gamma$ lies in the kernel of (4.32) will be called a *1-cycle*. The class in $H_1(\Gamma, M)$ associated to a 1-cycle \mathcal{C} will be denoted $[\mathcal{C}]$.

Given a real quadratic field F and ideals $\mathfrak{a}, \mathfrak{f}$ as in Section 4.1.3, the associated data $\gamma, P(x, y)$, and v give rise to a 1-cycle for Γ in \mathcal{M}^\vee as follows. Let $\varphi_{P,v} \in \mathcal{M}^\vee$ be given by evaluation at P, v :

$$\varphi_{P,v}(f) := f(P, v). \quad (4.33)$$

Define a chain

$$\mathcal{C}_{P,v,r} := (1 - [\gamma]) \otimes \varphi_{P^{r-1},v} \in I_\Gamma \otimes \mathcal{M}^\vee.$$

Note that for any $g \in \Gamma$, our definitions imply $g\varphi_{P,v} = \varphi_{g^{-1}P,gv}$. The fact that $\gamma^t P = P$ and $\gamma^{-1}v = v$ implies that \mathcal{C} is in fact a 1-cycle, i.e. it lies in the kernel of (4.32). The homology class $[\mathcal{C}_{P,v,r}] \in H_1(\Gamma, \mathcal{M}^\vee)$ depends only on $\mathfrak{a}, \mathfrak{f}$, and r , and not the choice of basis $\{w_1, w_2\}$. There is a canonical pairing

$$H^1(\Gamma, \mathcal{M}) \times H_1(\Gamma, \mathcal{M}^\vee) \longrightarrow \mathbf{C}$$

given by

$$\left\langle [\Psi], \left[\sum ([A_1] - [A_2]) \otimes \varphi \right] \right\rangle = \sum \varphi(\Psi(A_1^{-1}A_2)).$$

Siegel's theorem can then be stated

$$\zeta_{K/F,R}(\sigma_{\mathfrak{a}}, 1 - r) = \langle [\Psi_\tau], [\mathcal{C}_{P,v,r}] \rangle \in \mathbf{C}.$$

⁴To prove this description of $H_1(\Gamma, M)$, tensor the exact sequence of Γ modules

$$0 \longrightarrow I_\Gamma \longrightarrow \mathbf{Z}[\Gamma] \longrightarrow \mathbf{Z} \longrightarrow 0$$

with M and take the long exact sequence in homology. The module $\mathbf{Z}[\Gamma] \otimes M$ is induced and hence has trivial H_1 ; the result follows. Note that the composed map $(I_\Gamma \otimes M)_\Gamma \rightarrow M$ in (4.32) is given explicitly by $\sum([\gamma_1] - [\gamma_2]) \otimes m \mapsto \sum(\gamma_1^{-1}m - \gamma_2^{-1}m)$.

One appeal of this formulation of Siegel’s theorem is that it demonstrates that the formula for $\zeta_{K/F,R}(\sigma_{\mathfrak{a}}, 1 - r)$ depends only on the cohomology class $[\Psi_{\tau}]$. Though it is not clear from our current presentation, we will show below that there is a cocycle Ψ representing the class $[\Psi_{\tau}]$ that assumes *rational* values, i.e. $\Psi(\gamma)(P, v) \in \mathbf{Q}$ for all $\gamma \in \Gamma$, $P \in \mathcal{P}$ and $v \in \mathcal{V}$. This will imply the classical theorem (also due to Siegel) that the values $\zeta_{K/F,R}(\sigma_{\mathfrak{a}}, 1 - r)$ are rational for positive integers r .⁵

4.1.6 Smoothing

We now introduce a prime ℓ to “smooth” the cocycle Ψ_{τ} . Not only will this allow us to define a representative cocycle that achieves *rational* values, we will in fact show that certain specializations of this cocycle lie in $\mathbf{Z}[\frac{1}{\ell}]$. On the zeta function side of Siegel’s formula, the prime ℓ will correspond to a prime that splits in the real quadratic field F ; making a choice of prime ideal $\mathfrak{c} \subset \mathcal{O}_F$ with norm ℓ , we will take the smoothing set $T = \{\mathfrak{c}\}$.

Define $\mathcal{V}_{\ell} := \mathbf{Q}^2 - (\frac{1}{\ell}\mathbf{Z} \times \mathbf{Z})$ modulo \mathbf{Z}^2 . For $v \in \mathcal{V}_{\ell}$ define

$$E_{k,v}^{(\ell)}(z) := \ell^{k-2} \cdot (E_{k,(\ell v_1, v_2)}(\ell z) - E_{k,v}(z)).$$

From (4.7), it follows that the $E_{k,v}^{(\ell)}$ are permuted by the weight k action of $\Gamma_0(\ell)$:

$$E_{k,v}^{(\ell)}|_{\gamma} = E_{k,\gamma^{-1}v}^{(\ell)}, \quad \gamma \in \Gamma_0(\ell). \tag{4.34}$$

In particular, each individual $E_{k,v}^{(\ell)}$ is a modular form of weight k on $\Gamma_0(\ell) \cap \Gamma(N)$, where N is the denominator of v . The purpose of ℓ -smoothing is that the constant term of $E_{k,v}^{(\ell)}(z)$ vanishes at the cusp ∞ by (4.4). The constant term of $E_{2,v}^{(\ell)}(z)$ also vanishes at the cusp $\gamma\infty$ for each $\gamma \in \Gamma_0(\ell)$ by (4.34).

We define for $\gamma \in \Gamma_0(\ell)$, $v \in \mathcal{V}_{\ell}$, $\tau \in \mathcal{H}$ and a homogeneous $P \in \mathcal{P}$ of degree d , the period

$$\Psi_{\ell,\tau}(\gamma)(P, v) = \frac{(d+1)!}{(2\pi i)^{d+2}} \int_{\tau}^{\gamma\tau} P(z, 1) E_{d+2,v}^{(\ell)}(z) dz \in \mathbf{C}.$$

The fact that the constant term of $E_{d+2,v}^{(\ell)}(z)$ vanishes at the cusps ∞ and $\gamma\infty$ implies that the integral above converges as $\tau \rightarrow \infty$, i.e. the integral:

$$\Psi_{\ell}(\gamma)(P, v) = \Psi_{\ell,\infty}(\gamma)(P, v) := \frac{(d+1)!}{(2\pi i)^{d+2}} \int_{\infty}^{\gamma\infty} P(z, 1) E_{d+2,v}^{(\ell)}(z) dz \tag{4.35}$$

is well-defined. The remarkable fact is that the values in (4.35) can be shown to be rational numbers. In fact, an even stronger result holds (see Theorem 4.4 below); before stating this result, we first show that Ψ_{ℓ} is a 1-cocycle. Let \mathcal{M}_{ℓ} be defined the same as \mathcal{M} (see the beginning of Section 4.1.4) with \mathcal{V} replaced by \mathcal{V}_{ℓ} . The abelian group \mathcal{M}_{ℓ} is a $\Gamma_0(\ell)$ -module.

⁵Since we are avoiding the difficulties associated to $v = (0, 0)$, our proof will only hold under the additional assumption $\mathfrak{f} \neq 1$. One can handle the case $\mathfrak{f} = 1$ as well by enlarging the module \mathcal{M} and generalizing our cocycle Ψ . This is discussed in Section 4.5.

Proposition 4.3. *The function Ψ_ℓ is a 1-cocycle on $\Gamma_0(\ell)$ valued in \mathcal{M}_ℓ :*

$$\Psi_\ell \in Z^1(\Gamma_0(\ell), \mathcal{M}_\ell).$$

Proof. Let

$$\pi_\ell = \begin{pmatrix} \ell & 0 \\ 0 & 1 \end{pmatrix}. \quad (4.36)$$

For any $\tau \in \mathcal{H}$ and homogeneous $P \in \mathcal{P}$ of degree d , we have

$$\ell^{-d} \cdot \Psi_{\ell, \tau}(\gamma)(P, v) = \Psi_{\pi_\ell \tau}(\pi_\ell \gamma \pi_\ell^{-1})(\pi_\ell^{-1} P, \pi_\ell v) - \ell \Psi_\tau(\gamma)(P, v). \quad (4.37)$$

The fact that $\Psi_{\ell, \tau}$ is a cocycle on $\Gamma_0(\ell)$ valued in \mathcal{M}_ℓ follows formally from the fact that Ψ_τ is a 1-cocycle on Γ together with (4.37) and the observation that conjugation by π_ℓ sends $\Gamma_0(\ell)$ into Γ . We leave this as an exercise: prove that

$$\Psi_{\ell, \tau}(AB) = \Psi_{\ell, \tau}(A) + A \Psi_{\ell, \tau}(B)$$

for $A, B \in \Gamma_0(\ell)$ using (4.31) and (4.37). Taking the limit as $\tau \rightarrow i\infty$ gives the desired result for Ψ_ℓ . \square

The integrality result that we would like to state is best presented in terms of the pairing between cohomology and homology introduced in Section 4.1.5. Let $H_1(\Gamma_0(\ell), \mathcal{M}_\ell^\vee)_{\text{int}}$ denote the subgroup of $H_1(\Gamma_0(\ell), \mathcal{M}_\ell^\vee)$ generated by the 1-chains

$$\mathcal{C} = ([A_1] - [A_2]) \otimes \varphi_{P, v} \in I_{\Gamma_0(\ell)} \otimes \mathcal{M}_\ell^\vee$$

(see (4.33)) with $A_i \in \Gamma_0(\ell)$, $P \in \mathcal{P}$, and $v \in \mathcal{V}_\ell$ such that:

- we have

$$A_1^t P = A_2^t P \text{ and } A_1^{-1} v = A_2^{-1} v; \quad (4.38)$$

- P homogeneous and satisfies

$$P(v + \frac{1}{\ell} \mathbf{Z} \oplus \mathbf{Z}) \subset \mathbf{Z}[\frac{1}{\ell}]. \quad (4.39)$$

Condition (4.38) ensures that the 1-chain \mathcal{C} is in fact a 1-cycle.

Theorem 4.4. *The value $\Psi_\ell(\gamma)(P, v)$ is a rational number for any $\gamma \in \Gamma_0(\ell)$, $P \in \mathcal{P}$, $v \in \mathcal{V}$. Furthermore,*

$$\langle [\Psi_\ell], [\mathcal{C}] \rangle \in \mathbf{Z}[\frac{1}{\ell}]$$

for any $[\mathcal{C}] \in H_1(\Gamma_0(\ell), \mathcal{M}_\ell^\vee)_{\text{int}}$.

We will not prove this fact in this article, but we refer the reader to [8] and [10] for similar results. As mentioned before, we will take a different approach to the Eisenstein cocycle due to Sczech and prove Theorem 4.4 in this setting.

Let us now present an ℓ -smoothed version of Siegel's theorem. Suppose that the prime ℓ splits or ramifies in the real quadratic field F , and that ℓ is relatively prime to \mathfrak{f} . Let \mathfrak{c}

denote a prime ideal of \mathcal{O}_F of norm ℓ , and let $T = \{\mathfrak{c}\}$. Choose an oriented basis $\{w_1, w_2\}$ of $\mathfrak{a}^{-1}\mathfrak{f}$ such that $\{\frac{1}{\ell}w_1, w_2\}$ is a basis of $\mathfrak{a}^{-1}\mathfrak{c}^{-1}\mathfrak{f}$. Let ε be a fundamental totally positive unit congruent to 1 (mod \mathfrak{f}) such that $0 < \varepsilon < 1$ in our fixed real embedding of F . If γ is the matrix for multiplication by ε with respect to the row vector $\{w_1, w_2\}$ as in (4.14), then $\gamma \in \Gamma_0(\ell)$. Let $P(x, y) \in \mathbf{Z}[x, y]$ be defined by

$$P(x, y) = N(\mathfrak{a}) \text{Norm}_{F/\mathbf{Q}}(xw_1 + yw_2), \quad (4.40)$$

and define $v \in \mathbf{Q}^2$ by

$$1 = v_1w_1 + v_2w_2. \quad (4.41)$$

Note that $v \notin \frac{1}{\ell}\mathbf{Z} \oplus \mathbf{Z}$ if $\mathfrak{f} \neq 1$. The pair (P, v) satisfy the integrality criterion (4.39) of Theorem 4.4 (exercise), so together with γ they define the cycle

$$\mathcal{C}_{P,v,r} = ([1] - [\gamma]) \otimes \varphi_{P^{r-1},v} \quad (4.42)$$

yielding a class $[\mathcal{C}_{P,v,r}] \in H_1(\Gamma_0(\ell), \mathcal{M}_\ell^\vee)_{\text{int}}$.

We leave as an exercise the proof of the following ℓ -smoothed version of Siegel's Theorem, using (4.37) and Theorem 4.1:

Theorem 4.5. *For integers $r \geq 1$, we have*

$$\begin{aligned} \zeta_{K/F,R,T}(\sigma_{\mathfrak{a}}, 1-r) &= \Psi_\ell(\gamma)(P^{r-1}, v) \\ &= \langle [\Psi_\ell], [\mathcal{C}_{P,v,r}] \rangle. \end{aligned}$$

Combining with Theorem 4.4, one obtains

Theorem 4.6. *We have*

$$\zeta_{K/F,R,T}(\sigma_{\mathfrak{a}}, 1-r) \in \mathbf{Z}\left[\frac{1}{\ell}\right]$$

for all positive integers r .

This result was originally proven for real quadratic fields F by Coates and Sinnott [7], and for general totally real fields F by Deligne and Ribet [12], Pi. Cassou-Nogues [3], and Barsky [2], using different techniques.

4.2 Sczech's construction of the Eisenstein cocycle

Instead of calculating the integrals in (4.35) exactly and proving the integrality Theorem 4.4, we will instead provide a definition of the Eisenstein cocycle given by Sczech in [24] and refined by ℓ -smoothing in [5]. We will prove the analogue of Siegel's theorem using Sczech's definition of the Eisenstein cocycle directly, and prove the integrality Theorem 4.4 for an ℓ -smoothed version of Sczech's cocycle. The justification for adopting this approach is that Sczech's method generalizes to $n > 2$, and we describe this generalization at the end of this chapter. It may very well be the case that the method of integration of Eisenstein series generalizes to $n > 2$ as well, but this remains an open question.

The contents of Section 4.2 are all drawn from various papers of Sczech—[24], [23], [22].

4.2.1 Sczech's definition of Ψ

Sczech's method begins by integrating (4.3) in weight $k = 2$ formally, term by term, disregarding issues of convergence. We obtain

$$\int_{\tau}^{A\tau} E_{2,v}(z)dz = \sum'_{m,n} \frac{(A\tau - \tau)e(mv_1 + nv_2)}{(mA\tau + n)(m\tau + n)}.$$

Let us study this sum if we send $\tau \rightarrow \infty$, or more generally to a rational number r/s . We obtain, with $A = \begin{pmatrix} a & b \\ c & d \end{pmatrix}$, the sum

$$\sum'_{m,n} \frac{((ar + bs)s - (cr + ds)r)e(mv_1 + nv_2)}{(m(ar + bs) + n(cr + ds))(mr + ns)}. \quad (4.43)$$

There are two clear problems with this sum—(1) There are pairs (m, n) for which the denominator vanishes, namely those pairs orthogonal to the column vectors $\begin{pmatrix} r \\ s \end{pmatrix}$ or $A\begin{pmatrix} r \\ s \end{pmatrix}$; (2) even if these terms are excluded, the sum converges only conditionally, so we must specify an order in which to sum the terms.

To handle the first problem, complete the column vector $\begin{pmatrix} r \\ s \end{pmatrix}$ to a matrix

$$B = \begin{pmatrix} r & t \\ s & u \end{pmatrix} \in \Gamma.$$

If (m, n) is orthogonal to (r, s) , then it is necessarily *not* orthogonal to (t, u) since the matrix B is invertible. Hence we can replace $mr + ns$ with $mt + nu$. Similarly, if (m, n) is orthogonal to the first column of AB , then it is necessarily not orthogonal to the second column, and we may replace the dot product of (m, n) with the first column of AB in (4.43) by the dot product with the second column. The inclusion of these extra terms into the sum must seem artificial at this point; let us therefore make two comments. First, the inclusion of these terms allows one to prove that the resulting sum is a (homogeneous) 1-cocycle for Γ . Second, upon ℓ -smoothing, these extra terms will cancel out and hence can be ignored.

Therefore, for matrices $A_1, A_2 \in \Gamma$ and any vector $z \in \mathbf{R}^2 - \{0\}$ (these play the role of B, AB , and (m, n) in the discussion above, respectively), we define $\sigma_i = \sigma_i(z)$ to be the first column of the matrix A_i that is not orthogonal to z . Let $\sigma = (\sigma_1, \sigma_2)$. Consider the sum:⁶

$$\Psi(A_1, A_2)(1, v) := \frac{1}{(2\pi i)^2} \sum'_{z \in \mathbf{Z}^2} \frac{\det(\sigma)}{\langle z, \sigma_1 \rangle \langle z, \sigma_2 \rangle} \cdot e(\langle z, v \rangle). \quad (4.44)$$

Let us address the convergence of this sum. Let Q be a nondegenerate binary quadratic form over \mathbf{Q} with positive discriminant. For each real number t , the integer vectors $z \in \mathbf{Z}^2$ such that $|Q(z)| < t$ lie on the union of finitely many hyperbolas. On each hyperbola, it is easy

⁶Here and in the sequel, we view the elements $z \in \mathbf{Z}^2$ as row vectors. We write $\langle z, v \rangle$ for the usual dot product where z is a row vector and v is a column vector. In particular, for $\gamma \in \mathbf{GL}_2(\mathbf{R})$, we have $\langle z\gamma, v \rangle = \langle z, \gamma v \rangle$.

to see that the sum in (4.44) converges absolutely, since the denominator is quadratic in z . Therefore, the sum in (4.44) is well-defined if we restrict to the z such that $|Q(z)| < t$. We will show that the limit

$$\Psi(A_1, A_2)(1, v) := \frac{1}{(2\pi i)^2} \lim_{t \rightarrow \infty} \sum'_{\substack{z \in \mathbf{Z}^2 \\ |Q(z)| < t}} \frac{\det(\sigma)}{\langle z, \sigma_1 \rangle \langle z, \sigma_2 \rangle} \cdot e(\langle z, v \rangle) \quad (4.45)$$

exists. In fact, we will provide a finite closed form formula for $\Psi(A_1, A_2)(v)$ that shows that this value is a rational number that is independent of the choice of Q . Equation (4.45) gives Sczech's definition of the Eisenstein cocycle specialized to $P = 1$; we will show that it is a *homogeneous 1-cocycle* for Γ , which entails two properties:⁷

- $\Psi(\gamma A_1, \gamma A_2) = \gamma \Psi(A_1, A_2)$ for $\gamma, A_1, A_2 \in \Gamma$,
- $\Psi(A_1, A_2) - \Psi(A_1, A_3) + \Psi(A_2, A_3) = 0$ for $A_1, A_2, A_3 \in \Gamma$.

(A function satisfying the first property above is called a *homogeneous 1-cochain*. The second property is the *cocycle condition*.) At this point we can explain why we have chosen to introduce the quadratic form Q rather than the two more natural methods of evaluating conditionally convergent sums. Eisenstein summation is not preserved under the action of Γ , so it would not be clear how to establish that Ψ is a Γ -invariant cochain; under Hecke summation it is difficult to directly establish the cocycle condition. (See, however, the comments and footnote following the proof of Proposition 4.12.)

Let us now define the cocycle Ψ evaluated on a general homogeneous polynomial $P \in \mathcal{P}$ of degree d . In view of the equation (4.29) that has provided our motivation, we note that

$$P(-\partial_x, -\partial_y) \left(\frac{1}{(x\tau + y)^2} \right) = (d+1)! \frac{P(\tau, 1)}{(x\tau + y)^{d+2}}.$$

Therefore, we generalize from $P = 1$ to general P as follows. Let $A_1, A_2 \in \Gamma$. Recall that for $z = (x, y) \in \mathbf{R}^2 - \{0\}$ we defined $\sigma_i = \sigma_i(z)$ to be the first column of A_i that is not orthogonal to z . Write σ for the matrix with columns (σ_1, σ_2) . Define a function $\psi(A_1, A_2)$ on $\mathbf{R}^2 - \{0\}$ by

$$\psi(A_1, A_2)(z) = \frac{\det(\sigma)}{\langle z, \sigma_1 \rangle \langle z, \sigma_2 \rangle}.$$

Write

$$\psi(A_1, A_2)(P, z) := P(-\partial_x, -\partial_y) \psi(A_1, A_2)(z), \quad z = (x, y),$$

and define

$$\Psi(A_1, A_2)(P, v) := \frac{1}{(2\pi i)^{2+d}} \lim_{t \rightarrow \infty} \sum'_{\substack{z \in \mathbf{Z}^2 \\ |Q(z)| < t}} \psi(A_1, A_2)(P, z) \cdot e(\langle z, v \rangle). \quad (4.46)$$

⁷Recall that one recovers the more familiar "crossed homomorphism" definition of an *inhomogeneous 1-cocycle* via $c(\gamma) := \Psi(1, \gamma)$.

By specializing to the constant polynomial $P = 1$, we recover the special case given in (4.45). In the following sections, we will prove that this limit as $t \rightarrow \infty$ exists and is independent of Q , that the value of Ψ is a rational number, and that Ψ is a homogeneous 1-cocycle for Γ valued in \mathcal{M} . Then we will relate special values of Ψ to special values of classical and p -adic zeta functions of real quadratic fields.

Exercise: Prove that the function $\psi(A_1, A_2)(P, -)$ on $\mathbf{R}^2 - \{0\}$ has the following explicit formula. Write

$$(\sigma^t P)(x, y) = P((x, y)\sigma^t) = \sum_{r=0}^d P_r(\sigma) \frac{x^r y^{d-r}}{r!(d-r)!}. \quad (4.47)$$

Then

$$\psi(A_1, A_2)(P, z) = \sum_{r=0}^d \frac{P_r(\sigma) \det(\sigma)}{\langle z, \sigma_1 \rangle^{1+r} \langle z, \sigma_2 \rangle^{1+d-r}}. \quad (4.48)$$

Having defined Ψ , we can define an ℓ -smoothed version as follows. Recall the matrix π_ℓ defined in (4.36). If $A_1, A_2 \in \Gamma_0(\ell)$, then the matrices $A'_i := \pi_\ell A_i \pi_\ell^{-1}$ lie in Γ . For a homogeneous $P \in \mathcal{P}$ of degree d , define $P' = \pi_\ell^{-1} P$, i.e. $P'(x, y) = P(x/\ell, y)$. Similarly for $v \in \mathcal{V}_\ell$, let $v' = \pi_\ell v = (\ell v_1, v_2)$. Then we define

$$\Psi_\ell(A_1, A_2)(P, v) := \ell^d (\Psi(A'_1, A'_2)(P', v') - \ell \Psi(A_1, A_2)(P, v)). \quad (4.49)$$

The fact that $\Psi \in Z^1(\Gamma, \mathcal{M})$ implies that $\Psi_\ell \in Z^1(\Gamma_0(\ell), \mathcal{M}_\ell)$. This is essentially the same exercise, in homogenous form, as that given in the proof of Proposition 4.3.

4.2.2 A finite formula for Ψ

The key step in evaluating the sum (4.46) defining Ψ is the calculation of the following sum, for positive integers r, s :

$$\mathcal{B}_{r,s}(v, Q) := \lim_{t \rightarrow \infty} (2\pi i)^{-r-s} \sum'_{\substack{z \in \mathbf{Z}^2 \\ |Q(z)| \leq t}} \frac{e(\langle z, v \rangle)}{z_1^r z_2^s}. \quad (4.50)$$

Here the $'$ indicates that the sum extends over all $z \in \mathbf{Z}^2$ such that $z_1 z_2 \neq 0$. In addition to proving that this limit exists and is independent of Q , we will give an explicit formula for its value in terms of the periodic Bernoulli polynomials.

Theorem 4.7. *For $v \in \mathcal{V}$, the limit (4.50) exists and its value is given by*

$$\mathcal{B}_{r,s}(v) := \frac{\tilde{B}_r(v_1) \tilde{B}_s(v_2)}{r! s!}.$$

In particular the value is independent of Q .

Remark 4.8. If $v = (0, 0)$, Theorem 4.7 still holds unless $r = s = 1$; in this case, the limit (4.50) exists and is rational, but its value depends in a simple way on Q .

We prove Theorem 4.7 in the next section; for now, we show how it enables the proof of:

Theorem 4.9. *For $A_1, A_2 \in \Gamma$, $P \in \mathcal{P}$, and $v \in \mathcal{V}$, the limit*

$$\Psi(A_1, A_2)(P, v) = \frac{1}{(2\pi i)^{2+d}} \lim_{t \rightarrow \infty} \sum'_{\substack{z \in \mathbf{Z}^2 \\ |Q(z)| < t}} \psi(A_1, A_2)(P, z) \cdot e(\langle z, v \rangle) \quad (4.51)$$

exists, is independent of Q , and is a rational number. In fact, if we write the A_i in terms of their columns as $A_i = (\rho_i, \tau_i)$ and write $\rho = (\rho_1, \rho_2)$, then the value of Ψ is given by the formula

$$\Psi(A_1, A_2)(P, v) = \operatorname{sgn}(\det(\rho)) \sum_{r=0}^d P_r(\rho) \sum_{w \in \mathbf{Z}^2 / \rho \mathbf{Z}^2} \mathcal{B}_{1+r, 1+d-r}(\rho^{-1}(v+w)) \quad (4.52)$$

$$- \det(\tau_1, \rho_2) \sum_{r=0}^d \frac{P_r(\tau_1, \rho_2)}{\det(\rho)^{1+d-r}} \mathcal{B}_{0, 2+d}(A_1^{-1}v) \quad (4.53)$$

$$- \det(\rho_1, \tau_2) \sum_{r=0}^d \frac{P_r(\rho_1, \tau_2)(-1)^{1+r}}{\det(\rho)^{1+r}} \mathcal{B}_{0, 2+d}(A_2^{-1}v) \quad (4.54)$$

when $\det(\rho) \neq 0$, and

$$\Psi(A_1, A_2)(P, Q, v) = - \det(\tau_1, \tau_2) \sum_{r=0}^d \frac{P_r(\tau_1, \tau_2)}{\det(\tau_1, \rho_2)} \mathcal{B}_{0, 2+d}(A_1^{-1}v) \quad (4.55)$$

when $\det(\rho) = 0$.

Proof. Let us consider first the “main term” in the sum in (4.51), which arises from those $z \in \mathbf{Z}^2$ not orthogonal to either of the first columns ρ_1, ρ_2 of A_1, A_2 . The contribution to the value of Ψ from these z is given by

$$\frac{\det(\rho)}{(2\pi i)^{2+d}} \sum_{\substack{z \in \mathbf{Z}^2, \langle z, \rho_i \rangle \neq 0 \\ |Q(z)| < t}} \sum_{r=0}^d \frac{P_r(\rho) e(\langle z, v \rangle)}{\langle z, \rho_1 \rangle^{1+r} \langle z, \rho_2 \rangle^{1+d-r}}. \quad (4.56)$$

Changing the order of summation (in this absolutely convergent sum) and substituting the row vector $u = z\rho$ we obtain

$$\frac{\det(\rho)}{(2\pi i)^{2+d}} \sum_{r=0}^d P_r(\rho) \sum'_{\substack{u \in \mathbf{Z}^2 \rho \\ |(\rho^{-1}Q)(u)| < t}} \frac{e(\langle u, \rho^{-1}v \rangle)}{u_1^{1+r} u_2^{1+d-r}}. \quad (4.57)$$

To deal with the fact that the sum ranges over $\mathbf{Z}^2 \rho$ rather than \mathbf{Z}^2 , we introduce a character relation for $u \in \mathbf{Z}^2$:

$$\sum_{w \in \mathbf{Z}^2 / \rho \mathbf{Z}^2} e(\langle u, \rho^{-1}w \rangle) = \begin{cases} |\det \rho| & \text{if } u \in \mathbf{Z}^2 \rho \\ 0 & \text{if } u \notin \mathbf{Z}^2 \rho, \end{cases}$$

where the sum ranges over column vectors w representing $\mathbf{Z}^2/\rho\mathbf{Z}^2$. Therefore, (4.57) may be written

$$\frac{\operatorname{sgn}(\det(\rho))}{(2\pi i)^{2+d}} \sum_{r=0}^d P_r(\rho) \sum_{w \in \mathbf{Z}^2/\rho\mathbf{Z}^2} \sum'_{\substack{u \in \mathbf{Z}^2 \\ |(\rho^{-1}Q)(u)| < t}} \frac{e(\langle u, \rho^{-1}(v+w) \rangle)}{u_1^{1+r} u_2^{1+d-r}}.$$

The limit of the inner sum as $t \rightarrow \infty$ is seen to exist and be independent of Q by Theorem 4.7, giving the following rational value for (4.56):

$$\operatorname{sgn}(\det(\rho)) \sum_{r=0}^d P_r(\rho) \sum_{w \in \mathbf{Z}^2/\rho\mathbf{Z}^2} \mathcal{B}_{1+r,1+d-r}(\rho^{-1}(v+w)). \quad (4.58)$$

This is the term on line (4.52).

The determination of the other terms in the sum defining Ψ is easier. For instance, consider the terms $z \in \mathbf{Z}^2$ such that z is orthogonal to ρ_1 , but not to ρ_2 . Write $\rho_1 = \begin{pmatrix} a \\ b \end{pmatrix}$. The set of integer tuples orthogonal to ρ_1 is the set of multiples of $\rho_1^\perp := \begin{pmatrix} -b \\ a \end{pmatrix}$, and these vectors are not orthogonal to ρ_2 precisely when $\det(\rho) \neq 0$. We assume this holds and obtain the following sum as the contribution to Ψ :

$$\frac{\det(\tau_1, \rho_2)}{(2\pi i)^{2+d}} \sum'_{\substack{k \in \mathbf{Z} \\ |k| < t'}} \sum_{r=0}^d \frac{P_r(\tau_1, \rho_2) e(k \langle \rho_1^\perp, v \rangle)}{k^{1+r} (k \cdot \det \rho)^{1+d-r}}.$$

Here we have written $t' = t/|Q(-b, a)|$. Taking the limit as $t \rightarrow \infty$ and applying (4.6), we obtain the value

$$-\det(\tau_1, \rho_2) \sum_{r=0}^d \frac{P_r(\tau_1, \rho_2)}{\det(\rho)^{1+d-r}} \cdot \frac{\tilde{B}_{2+d}(\langle \rho_1^\perp, v \rangle)}{(d+2)!} \in \mathbf{Q}, \quad (4.59)$$

giving the term on line (4.53). Similarly, one finds that the contribution to Ψ of the $z \in \mathbf{Z}^2$ not orthogonal to ρ_1 but orthogonal to ρ_2 is given by the term (4.54). Finally, we note that there exist $z \in \mathbf{Z}^2 - \{0\}$ orthogonal to both ρ_1 and ρ_2 precisely when $\det(\rho) = 0$. When this holds, we have seen that the terms above offer no contribution to Ψ , whereas the contribution of these z to Ψ is calculated to be (4.55). \square

For an integer matrix ρ and $v \in \mathbf{Q}^2/\mathbf{Z}^2$, define the *Dedekind sum*

$$\mathcal{D}_{r,s}(\rho, v) := \operatorname{sgn}(\det(\rho)) \sum_{w \in \mathbf{Z}^2/\rho\mathbf{Z}^2} \mathcal{B}_{r,s}(\rho^{-1}(v+w)),$$

with the convention that this value is zero if $\det(\rho) = 0$. The main term (4.52) in Theorem 4.9 can be written succinctly as

$$\sum_{r=0}^d P_r(\rho) \mathcal{D}_{1+r,1+d-r}(\rho, v).$$

We conclude this section by giving a similar formula for the ℓ -smoothed cocycle $\Psi_\ell \in Z^1(\Gamma_0(\ell), \mathcal{M}_\ell)$. Given $A_1, A_2 \in \Gamma_0(\ell)$, let ρ_i denote the first column of A_i and write $\rho = (\rho_1, \rho_2)$. Since each $A_i \in \Gamma_0(\ell)$, the matrix

$$\rho_\ell := \frac{1}{\ell} \pi_\ell \rho$$

has integer entries. The matrix ρ_ℓ is simply the matrix of first columns of the matrices $A'_i = \pi_\ell A_i \pi_\ell^{-1}$. Define the ℓ -smoothed Dedekind sum

$$\mathcal{D}_{r,s}^\ell(\rho, v) := \mathcal{D}_{r,s}(\rho_\ell, \pi_\ell v) - \ell^{r+s-1} \mathcal{D}_{r,s}(\rho, v). \quad (4.60)$$

Theorem 4.10. *Let P be homogeneous of degree d . We have*

$$\Psi_\ell(A_1, A_2)(P, v) = \sum_{r=0}^d P_r(\rho) \mathcal{D}_{1+r, 1+d-r}^\ell(\rho, v). \quad (4.61)$$

Proof. Recall the definition of Ψ_ℓ from (4.49). The right side of (4.61) is the contribution of the main terms of $\Psi(A_1, A_2)$ and $\Psi(A'_1, A'_2)$ arising from (4.52). The ℓ -smoothing cancels the other terms. This can be shown directly from the formulas (4.53)–(4.55), but we provide another, more conceptual argument.

Consider the 4 pairs of tuples $e = (e_1, e_2)$ with $e_i = 1, 2$. Let $X(e)$ denote the set of pairs $z \in \mathbf{Z}^2 - \{0\}$ such that for $i = 1, 2$, the first column of A_i not orthogonal to z is the e_i th one; define $X'(e)$ using A'_1, A'_2 similarly. The pair $e = (1, 1)$ corresponds to the main term. We will show that for $e \neq (1, 1)$, the contribution of the $X(e)$ to $\ell \cdot \Psi(A_1, A_2)$ cancels the contribution of the $X'(e)$ to $\Psi(A'_1, A'_2)$. Indeed, the map

$$\pi_\ell : z = (x, y) \longmapsto z\pi_\ell = (\ell x, y)$$

gives a bijection between $X'(e)$ and $X(e)$. (Exercise: Prove this fact. The only non-trivial part is surjectivity; this is where one uses $e \neq (1, 1)$ and the fact that $A_i \in \Gamma_0(\ell)$.) Under this bijection, the terms in the definition of $\Psi(A'_1, A'_2)$ and $\ell \cdot \Psi(A_1, A_2)$ (see (4.46) and (4.48)) match up for $z \in X'(e)$ and $z\pi_\ell \in X(e)$; writing $(r, d-r) = (r_1, r_2)$ and $\Sigma(r, e) := \sum_{i: e_i=1} r_i$, we have:

$$\begin{aligned} P'_r(\sigma') &= P_r(\sigma) \cdot \ell^{-\Sigma(r, e)}, \\ \langle z, \sigma'_i \rangle &= \begin{cases} \langle z\pi_\ell, \sigma_i \rangle & \text{if } e_i \neq 1 \\ \ell^{-1} \langle z\pi_\ell, \sigma_i \rangle & \text{if } e_i = 1, \end{cases} \\ \det(\sigma') &= \ell^{1-\#\{i: e_i=1\}} \det(\sigma). \end{aligned}$$

Combining these equalities gives for $z \in X'(e)$:

$$\sum_{r=0}^d \frac{P'_r(\sigma') \det(\sigma') e(\langle z, \pi_\ell v \rangle)}{\langle z, \sigma'_i \rangle^{1+r} \langle z, \sigma'_i \rangle^{1+d-r}} = \ell \cdot \sum_{r=0}^d \frac{P_r(\sigma) \det(\sigma) e(\langle z\pi_\ell, v \rangle)}{\langle z\pi_\ell, \sigma_i \rangle^{1+r} \langle z\pi_\ell, \sigma_i \rangle^{1+d-r}}.$$

Summing over $z \in X'(e)$, the terms from $X'(e)$ and $X(e)$ cancel out as desired. (In the application of (4.46), we must use $Q(z)$ on the left and $Q(z\pi_\ell)$ on the right and invoke the independence of the final result on the choice of Q .) \square

4.2.3 Proof of Theorem 4.7

In this section we prove that for positive integers r, s , the limit

$$\mathcal{B}_{r,s}(Q, v) = \lim_{t \rightarrow \infty} (2\pi i)^{-r-s} \sum'_{\substack{z \in \mathbf{Z}^2 \\ |Q(z)| \leq t}} \frac{e(\langle z, v \rangle)}{z_1^r z_2^s}.$$

has the explicit evaluation

$$\mathcal{B}_{r,s}(v) = \frac{\tilde{B}_r(v_1) \tilde{B}_s(v_2)}{r!s!} \quad (4.62)$$

under the assumption $v \in \mathcal{V}$ when $r = s = 1$. We first remark that the desired evaluation holds easily using Eisenstein summation, i.e.

$$\lim_{M \rightarrow \infty} \sum'_{z_1 = -M}^M \left(\lim_{N \rightarrow \infty} \sum'_{z_2 = -N}^N (2\pi i)^{-r-s} \frac{e(\langle z, v \rangle)}{z_1^r z_2^s} \right) = \frac{\tilde{B}_r(v_1) \tilde{B}_s(v_2)}{r!s!}$$

by (4.6). Our summation method using Q , however, significantly complicates the situation. Instead of directly calculating $\mathcal{B}_{r,s}(v)$, we will study for $(u, w) \in \mathbf{Q}^2$ the limit

$$\mathcal{S}_{r,s}(u, w, Q) := \lim_{t \rightarrow \infty} \sum'_{\substack{z \in \mathbf{Z}^2 + (u, w) \\ |Q(z)| \leq t}} \frac{1}{z_1^r z_2^s}.$$

We can then recover $\mathcal{B}_{r,s}(v)$ by the formula

$$\mathcal{B}_{r,s}\left(\frac{a}{N}, \frac{b}{N}, Q\right) = (2N\pi i)^{-r-s} \sum_{i,j=0}^N e\left(\frac{ai + bj}{N}\right) \mathcal{S}_{r,s}\left(\frac{i}{N}, \frac{j}{N}, Q\right). \quad (4.63)$$

Without loss of generality, fix u, w such that $0 \leq u, w < 1$. Denote by L the set of pairs $(x, y) \in \mathbf{Z}^2 + (u, w)$ such that $xy \neq 0$. For a positive real number t , let

$$X(t) = \{z \in \mathbf{R}^2 : |Q(z)| < t\}.$$

We partition $X(t)$ into its ‘‘symmetric part’’ $S(t)$ and ‘‘asymmetric part’’ $A(t)$ as drawn in the diagram below.

In inequalities,

$$\begin{aligned} S(t) &:= \{(x, y) \in \mathbf{R}^2 : |Q(x, y)| < t, |Q(x, -y)| < t\} \\ A(t) &:= \{(x, y) \in \mathbf{R}^2 : |Q(x, y)| < t \leq |Q(x, -y)|\}, \\ X(t) &= S(t) \sqcup A(t). \end{aligned}$$

Write $X(t, L) = X(t) \cap L$, etc. With the exclusion of points near the boundary or near the axes, we can associate to every point

$$(x, y) = (p + u, q + w) \in S(t, L), \quad (p, q) \in \mathbf{Z}^2,$$

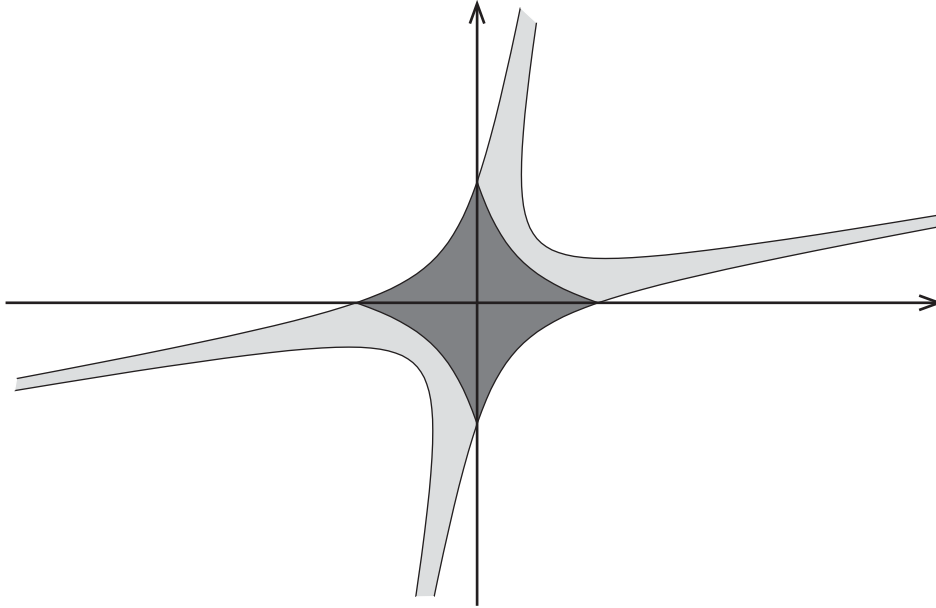
Figure 4.1: The symmetric part $S(t)$ and asymmetric part $A(t)$ of $X(t)$ 

three other points in $S(t, L)$, namely

$$(-p + u, q + w), (-p + u, -q + w), (p + u, -q + w).$$

The contribution to $\mathcal{S}_{r,s}(u, w)$ of these four points is $O(p^{-2}q^{-2})$. For example, if $r = s = 1$, the sum of $1/xy$ over these four points is

$$\frac{4uw}{(u^2 - p^2)(w^2 - q^2)},$$

and our claim is even easier to prove if r or s is greater than 1. Thus the contribution to $\mathcal{S}_{r,s}(u, w)$ provided by $S(t, L)$ is an absolutely convergent sum (we leave as an exercise the verification that the sum of the excluded points “near the boundary or axes” is absolutely convergent as well). In the limit, $S(t)$ encompasses the whole plane, so the limit as $t \rightarrow \infty$ may be computed over any region that is symmetric with respect to the axes and in the limit covers the entire plane. In particular, if we choose to sum over the boxes

$$\{(x, y) \in \mathbf{R}^2 : |x|, |y| < t\},$$

we obtain the Eisenstein sum:

$$\lim_{t \rightarrow \infty} \sum_{z \in S(t, L)} \frac{1}{x^r y^s} = c_r(u) c_s(w),$$

where c_r are the periodic functions⁸

$$c_r(u) := \lim_{N \rightarrow \infty} \sum'_{k=-N}^N \frac{1}{(k+u)^r}.$$

It remains to deal with the sum over $A(t, L)$. Let us first treat the case $r = s = 1$. We have

$$\sum_{(x,y) \in A(t,L)} \frac{1}{xy} = \frac{1}{t^2} \sum_{(x,y) \in A(1, \frac{1}{t}L)} \frac{1}{xy}.$$

Interpreting the right side as a Riemann sum, we recognize the limit as $t \rightarrow \infty$ as the integral

$$I_Q := \int_{A(1)} \frac{dxdy}{xy}. \tag{4.64}$$

The key point in this argument is that the improper integral I_Q converges absolutely (exercise), whereas the same is not true for the integral over $X(1)$; this explains the need to extract the symmetric region $S(t)$ from $X(t)$.

A key component of Sczech's thesis is the determination of the integral I_Q . Incredibly, the integral always has the value $0, \pi^2$, or $-\pi^2$, depending on Q .⁹ For our purposes, we will not need the exact value of I_Q , but only the fact that it depends only on Q and not on the pair (u, w) . We have shown that

$$\mathcal{S}_{1,1}(u, w, Q) = c_1(u)c_1(w) + I_Q. \tag{4.65}$$

If $(r, s) \neq (1, 1)$, then a similar argument applies, but we must be careful to deal with the fact that the integral $\int_{A(1)} dxdy/(x^r y^s)$ does not converge because of the singularities on the axes. We fix an $\varepsilon > 0$ and let

$$A_\varepsilon(t) := \{(x, y) \in A(t) : |x| \leq \varepsilon t \text{ or } |y| \leq \varepsilon t\}.$$

An elementary estimate shows that

$$\lim_{t \rightarrow \infty} \sum_{(x,y) \in A_\varepsilon(t,L)} \frac{1}{x^r y^s} = 0$$

if $(r, s) \neq (1, 1)$. On the complementary region $A'_\varepsilon(t) = A(t) - A_\varepsilon(t)$ we have

$$\sum_{(x,y) \in A'_\varepsilon(t,L)} \frac{1}{x^r y^s} = \frac{1}{t^{r+s-2}} \left(\frac{1}{t^2} \sum_{(x,y) \in A'_\varepsilon(1, \frac{1}{t}L)} \frac{1}{x^r y^s} \right). \tag{4.66}$$

⁸For $u \notin \mathbf{Z}$ the c_r have expressions in terms of standard trigonometric functions. For example, $c_1(u) = \pi \cot(\pi u)$. We have $\frac{d}{du} c_r(u) = -r c_{r+1}(u)$, hence $c_2(u) = \pi^2 \sin^{-2}(\pi u)$. For $u \in \mathbf{Z}$, we have $c_r(\mathbf{Z}) = 0$ for r odd and $c_r(\mathbf{Z}) = 2\zeta(r)$ for r even.

⁹More precisely, factor $Q(x, y) = c(\alpha x + y)(\alpha' x + y)$. Then $I_Q = (\text{sgn}(\alpha) + \text{sgn}(\alpha')) \cdot \pi^2/4$.

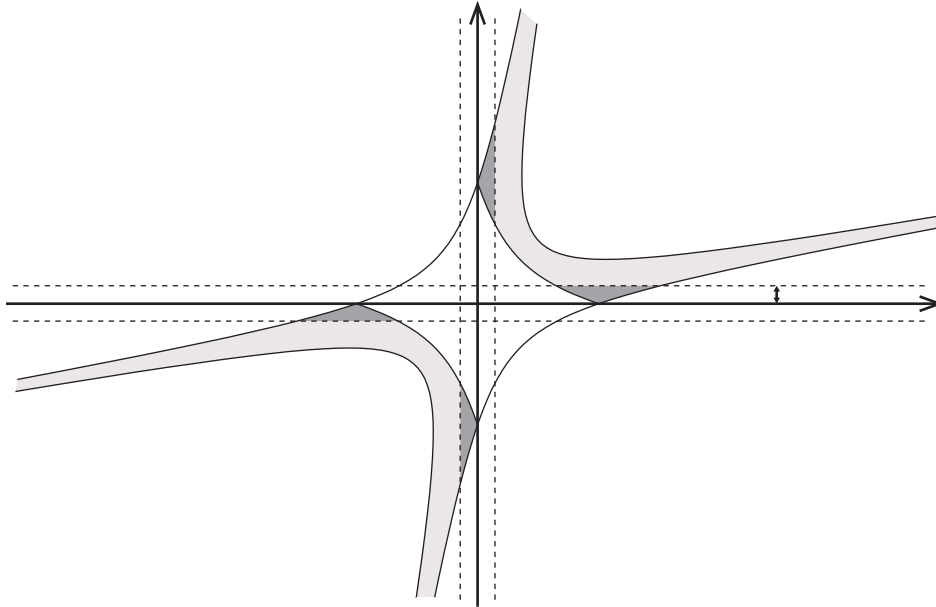
Figure 4.2: Excising the portion of $A(t)$ within εt of the axes

The sum in parenthesis can again be recognized as a Riemann sum whose limit as $t \rightarrow \infty$ is the convergent integral $\int_{A_\varepsilon(1)} dx dy / (x^r y^s)$. The extra factor $1/t^{r+s-2}$ causes the value (4.66) to vanish as $t \rightarrow \infty$ when $(r, s) \neq (1, 1)$. Therefore for $(r, s) \neq (1, 1)$, we have

$$\mathcal{S}_{r,s}(u, w, Q) = c_r(u)c_s(w). \quad (4.67)$$

The desired result (4.62) now follows from (4.63), (4.65), and (4.67) using the Fourier expansion (4.6) of the periodic Bernoulli polynomials. Note in particular that in the case $(r, s) = (1, 1)$, the terms involving I_Q cancel in the sum over all i, j in (4.63), since $(a, b) \notin N\mathbf{Z}^2$, i.e. since $v \neq 0$ in $(\mathbf{Q}/\mathbf{Z})^2$. Our calculation holds with an extra term involving I_Q in the case $v = 0$, $r = s = 1$. It is possible to make a cocycle that includes the possibility $v = 0$, but the module of coefficients \mathcal{M} must be enlarged to allow for the mild dependence on Q caused by the term I_Q . This is discussed in greater detail in Section 4.5.

4.2.4 The cocycle properties

In this section, we prove that $\Psi \in Z^1(\Gamma, \mathcal{M})$. The Γ -invariance property of Ψ is easy to verify.

Proposition 4.11. *For $\gamma, A_1, A_2 \in \Gamma, P \in \mathcal{P}, v \in \mathcal{V}$, we have*

$$\Psi(\gamma A_1, \gamma A_2)(P, v) = \Psi(A_1, A_2)(\gamma^t P, \gamma^{-1} v).$$

Proof. The Γ -invariance property

$$\psi(\gamma A_1, \gamma A_2)(P, z) = \psi(A_1, A_2)(\gamma^t P, z\gamma) \quad (4.68)$$

follows directly from (4.48). The desired result now follows from the definition (4.46) and the fact that the value of Ψ is independent of the Q used to define it (use $Q(z)$ on the left and $Q(z\gamma^{-1})$ on the right). \square

The cocycle condition is more interesting.

Proposition 4.12. *For $A_1, A_2, A_3 \in \Gamma$, we have*

$$\Psi(A_1, A_2) - \Psi(A_1, A_3) + \Psi(A_2, A_3) = 0.$$

Proof. Given fixed $z \in \mathbf{Z}^2 - \{0\}$, the contribution of z to $\Psi(A_i, A_j)$ is a constant (depending on z but not the A_i) times $\psi(A_i, A_j)(P, z)$. Therefore it suffices to prove that

$$\psi(A_1, A_2)(P, z) - \psi(A_1, A_3)(P, z) + \psi(A_2, A_3)(P, z) = 0. \quad (4.69)$$

We stress that it is crucial in this argument that region of the sum, namely $|Q(z)| < t$, is independent of the A_i .¹⁰

For each matrix A_i we let σ_i denote the first column not orthogonal to z . Equation (4.69) for $P = 1$ reads:

$$\frac{\det(\sigma_1, \sigma_2)}{\langle z, \sigma_1 \rangle \langle z, \sigma_2 \rangle} - \frac{\det(\sigma_1, \sigma_3)}{\langle z, \sigma_1 \rangle \langle z, \sigma_3 \rangle} + \frac{\det(\sigma_2, \sigma_3)}{\langle z, \sigma_2 \rangle \langle z, \sigma_3 \rangle} = 0. \quad (4.70)$$

We will prove (4.70) for all $z \in \mathbf{R}^2$ such that the denominators do not vanish; equation (4.69) then holds for general P by applying the differential operator $P(-\partial_x, -\partial_y)$ to equation (4.70), where $z = (x, y)$. To prove equation (4.70), note that

$$\det \begin{pmatrix} \langle z, \sigma_1 \rangle & \langle z, \sigma_2 \rangle & \langle z, \sigma_3 \rangle \\ \sigma_1 & \sigma_2 & \sigma_3 \end{pmatrix} = 0$$

since the first row is a linear combination of the last two. Dividing by $\prod_{i=1}^3 \langle z, \sigma_i \rangle$ gives the desired result. \square

We have proven that $\Psi \in Z^1(\Gamma, \mathcal{M})$; as mentioned before, this implies formally that $\Psi_\ell \in Z^1(\Gamma_0(\ell), \mathcal{M}_\ell)$.

4.2.5 Relationship with zeta functions

In this section, we prove that with Sczech's definition of the Eisenstein cocycle, Siegel's formula still holds. First we need a lemma. Let $\sigma \in M_2(\mathbf{R})$ have nonzero columns σ_1, σ_2 . Let $z \in \mathbf{Z}^2$ be such that $\langle z, \sigma_i \rangle \neq 0$ for $i = 1, 2$. For a homogeneous polynomial P of degree d , define $f(\sigma)(P, z)$ by the right side of (4.48):

$$f(\sigma)(P, z) = \sum_{r=0}^d \frac{P_r(\sigma) \det(\sigma)}{\langle z, \sigma_1 \rangle^{r+1} \langle z, \sigma_2 \rangle^{d-r+1}},$$

¹⁰Therefore, if one tries to regularize the sum defining Ψ by some other method, such as Hecke's method of multiplying by $|\text{denominator}|^s$ and analytically continuing to $s = 0$, then this proof of the cocycle relation would need to be altered in a significant way. In our setting, the Hecke summation method does produce the same explicit formula for Ψ in terms of Dedekind sums for $v \in \mathcal{V}$, and therefore gives a cocycle; but this is a quirk for dimension $n = 2$ and we do not know if this fact holds for $n \geq 3$.

with the $P_r(\sigma)$ as in (4.47). We mention two important features of the function f :

- The value of f is unchanged if either column of σ is scaled by a nonzero constant.
- For fixed P and z , f is a continuous function of σ on its domain in $M_2(\mathbf{R})$.

We now fix a real quadratic field F , integral ideals \mathfrak{a} and \mathfrak{f} , and let the notation be as in Section 4.1.3. In particular, $\{w_1^*, w_2^*\}$ is the dual basis to the oriented basis $\{w_1, w_2\}$ of $\mathfrak{a}^{-1}\mathfrak{f}$. Let

$$W = \begin{pmatrix} w_1^* & \overline{w_1^*} \\ w_2^* & \overline{w_2^*} \end{pmatrix} \in \mathbf{GL}_2(\mathbf{R}),$$

using our fixed chosen embedding $F \subset \mathbf{R}$. Recall the quadratic form P^* defined in (4.20):

$$P^*(x, y) = N(\mathfrak{a}^{-1}\mathfrak{f}\mathfrak{d}) N(xw_1^* + yw_2^*).$$

Lemma 4.13. *For every positive integer r , we have*

$$f(W)(P^{r-1}, z) = \frac{((r-1)!)^2 N\mathfrak{f}^{r-1} D^{r-1/2}}{P^*(z)^r}.$$

Proof. It is easy to verify that $P((x, y)W^t) = xy \cdot N\mathfrak{a}$. Hence $P_j^{r-1}(W) = 0$ for $j \neq r-1$, and $P_{r-1}^{r-1}(W) = ((r-1)!)^2 N\mathfrak{a}^{r-1}$ by (4.47). The result follows from the definition of P^* and the fact that $\det(W) = N\mathfrak{a}\mathfrak{f}^{-1}/\sqrt{D}$. \square

The following is Siegel's formula using Szezech's definition of the Eisenstein cocycle.

Theorem 4.14. *Let γ , P and v be defined as in (4.16), (4.17) and (4.18). For any positive integer r , we have*

$$\zeta_{K/F, R}(\sigma_{\mathfrak{a}}, 1-r) = \Psi(1, \gamma)(P^{r-1}, v).$$

Proof. In view of the proof of Theorem 4.1 (and maintaining the notation there), we must prove the analogue of equations (4.21)–(4.22) for the cocycle Ψ , namely

$$(2\pi i)^{2r} \Psi(1, \gamma)(P^{r-1}, v) = N\mathfrak{f}^{r-1} D^{r-1/2} ((r-1)!)^2 \zeta(P^*, \gamma^*, v, r). \quad (4.71)$$

Here the right side was defined in (4.23) for $r > 2$ and in (4.25) for $r = 1$.

Now

$$(2\pi i)^{2r} \Psi(1, \gamma)(P^{r-1}, v) = \lim_{t \rightarrow \infty} \sum'_{\substack{z \in \mathbf{Z}^2 \\ |Q(z)| < t}} \psi(1, \gamma)(P^{r-1}, z) e(\langle z, v \rangle). \quad (4.72)$$

Let us choose $Q = P^*$ in this limit; this choice implies that the region $|Q(z)| < t$ is preserved under the right action of γ on the row vectors \mathbf{R}^2 . Furthermore, since $\gamma v \equiv v \pmod{\mathbf{Z}^2}$, the value of $e(\langle z, v \rangle)$ is preserved under this action. We therefore let \mathcal{D}_t denote a set of representatives for the right action of γ on $\{z \in \mathbf{Z}^2 - \{0\} : |P^*(z)| < t\}$, and write the sum in (4.72) as

$$\sum_{z \in \mathcal{D}_t} e(\langle z, v \rangle) \sum_{k=-\infty}^{\infty} \psi(1, \gamma)(P^{r-1}, z\gamma^k). \quad (4.73)$$

Using the cocycle properties (4.68) and (4.69) of ψ and the fact that $\gamma^t P = P$, the inner sum in (4.73) can be recognized as the limit as $N \rightarrow \infty$ of a telescoping sum:

$$\begin{aligned} \sum_{k=-N+1}^N \psi(1, \gamma)(P^{r-1}, z\gamma^k) &= \sum_{k=-N+1}^N \psi(\gamma^{-k}, \gamma^{-k+1})((\gamma^{-k})^t P^{r-1}, z) \\ &= \sum_{k=-N+1}^N \psi(\gamma^{-k}, \gamma^{-k+1})(P^{r-1}, z) \\ &= \psi(\gamma^{-N}, \gamma^N)(P, z). \end{aligned} \quad (4.74)$$

Let τ_n denote the first column of γ^n . For z fixed, it is clear that τ_N and τ_{-N} are not orthogonal to z for N large enough (in fact, $\langle z, \tau_n \rangle = 0$ for at most one value of n). Therefore, if we let α_N denote the matrix with columns (τ_{-N}, τ_N) , then the right side of (4.74) may be written $f(\alpha_N)(P, z)$. Now we use the two properties of the function f noted earlier. One checks that

$$\tau_{-N} \cdot \frac{\varepsilon^N}{w_1} = \begin{pmatrix} w_1^* \\ w_2^* \end{pmatrix} + \frac{\varepsilon^{2N} \bar{w}_1}{w_1} \begin{pmatrix} \bar{w}_1^* \\ w_2^* \end{pmatrix}, \quad (4.75)$$

$$\tau_N \cdot \frac{\varepsilon^N}{w_1} = \begin{pmatrix} \bar{w}_1^* \\ w_2^* \end{pmatrix} + \frac{\varepsilon^{2N} w_1}{w_1} \begin{pmatrix} w_1^* \\ w_2^* \end{pmatrix}. \quad (4.76)$$

Since the function f is invariant under scaling of columns, we replace α_N by the matrix whose columns are given by the expressions on the right in (4.75), (4.76). By the continuity property of f , we see that the limit as $N \rightarrow \infty$ is simply $f(W)(P, z)$ since $0 < \varepsilon < 1$. Using Lemma 4.13, we obtain that the value of (4.73) is equal to

$$((r-1)!)^2 N f^{r-1} D^{r-1/2} \sum_{z \in \mathcal{D}_t} \frac{e(\langle z, v \rangle)}{P^*(z)^r}. \quad (4.77)$$

For $r > 1$, the sum in (4.77) converges absolutely over all $z \in (\mathbf{Z}^2 - \{0\})/\gamma$, so the limit as $t \rightarrow \infty$ is equal to $\zeta(P^*, \gamma^*, v, r)$ by definition (see (4.23)). For $r = 1$, write $\zeta(P^*, \gamma^*, v, 1, s)$ (see (4.24)) as a Dirichlet series $\sum_{n=1}^{\infty} a_n n^{-s}$. By definition of \mathcal{D}_t , the limit as $t \rightarrow \infty$ of the sum in (4.77) is the (only conditionally convergent) sum $\sum_{n=1}^{\infty} a_n$; meanwhile $\zeta(P^*, \gamma^*, v, 1)$ is defined to be the value of the analytic continuation of $\sum_{n=1}^{\infty} a_n n^{-s}$ at $s = 0$. By the version of Abel's Theorem for Dirichlet series (see [25]), these are equal. Therefore we obtain the desired equality (4.71) for all positive integers r . The proof now follows the remainder of the proof of Theorem 4.1. \square

4.3 Integrality of the ℓ -smoothed cocycle Ψ_ℓ

In this section, we prove the integrality property stated in Theorem 4.4 for the ℓ -smoothed cocycle Ψ_ℓ , using Szech's definition of Ψ . The idea of ℓ -smoothing Szech's cocycle was introduced in [5]; the contents of the rest of this chapter (except Section 4.5.1) are drawn from that paper.

Recall the definition of the integral subspace $H_1(\Gamma_0(\ell), \mathcal{M}_\ell^\vee)_{\text{int}}$ given in (4.39).

Theorem 4.15. *We have*

$$\langle [\Psi_\ell], [\mathcal{C}] \rangle \in \mathbf{Z}[\frac{1}{\ell}]$$

for any $[\mathcal{C}] \in H_1(\Gamma, \mathcal{M}_\ell^\vee)_{\text{int}}$.

Theorem 4.15 will be proven over the next three sections. As noted in our discussion of the modular symbol definition of Ψ_ℓ in Section 4.1.6, Theorems 4.14 and 4.15 imply the integrality result for partial zeta functions stated in Theorem 4.6. We restate the result below.

Theorem 4.16. *For integers $r \geq 1$, we have*

$$\begin{aligned} \zeta_{K/F,R,T}(\sigma_{\mathfrak{a}}, 1-r) &= \Psi_\ell(1, \gamma)(P^{r-1}, v) \\ &= \langle [\Psi_\ell], [\mathcal{C}_{P,v,r}] \rangle \in \mathbf{Z}[\frac{1}{\ell}]. \end{aligned}$$

4.3.1 A decomposition of the ℓ -smoothed Dedekind sum

We will prove Theorem 4.15 using the formula for Ψ_ℓ given in Theorem 4.10 by decomposing $\mathcal{D}_{r,s}^\ell(\rho, v)$ into a sum of terms that individually share an analogous integrality property. To this end, fix a linear map $L \in \text{Hom}(\mathbf{Z}^2, \mathbf{F}_\ell)$ such that $L \binom{1}{0}, L \binom{0}{1}$ are nonzero. For $x \in \mathbf{R}^2 - \mathbf{Z}^2$, $z \in \mathbf{F}_\ell$, and positive integers r, s , define

$$\mathcal{B}_{r,s}^{L,z}(x) := \mathcal{B}_{r,s}(x) - \ell^{r+s-1} \sum_{\substack{y \in \mathbf{F}_\ell^2 \\ L(y)=z}} \mathcal{B}_{r,s} \left(\frac{x+y}{\ell} \right), \quad (4.78)$$

where the summation runs over all $y \in \mathbf{F}_\ell^2$ such that $L(y) = z$. Note that $\mathcal{B}_{r,s}^{L,z}$ depends on $x \bmod \ell \mathbf{Z}^2$ rather than $\bmod \mathbf{Z}^2$, since the summation over y is restricted. It satisfies the following distribution relation for integers N relatively prime to ℓ :

$$\mathcal{B}_{r,s}^{L,Nz}(x) = N^{r+s-2} \sum_{k \in (\ell \mathbf{Z} / \ell N \mathbf{Z})^2} \mathcal{B}_{r,s}^{L,z} \left(\frac{x+k}{N} \right). \quad (4.79)$$

As in the previous section, consider $A_1, A_2 \in \Gamma_0(\ell)$ and let ρ denote the matrix consisting of the first columns of A_1, A_2 . We assume that $\det(\rho) \neq 0$ since otherwise $\mathcal{D}_{r,s}^\ell(\rho, v) = 0$. Recall the notation $\rho_\ell = \pi_\ell \ell^{-1} \rho$. Let R denote the first row of ρ and define $L(y) = \langle R, y \rangle \pmod{\ell}$. Our desired decomposition is:

Lemma 4.17. *Let $\{x = (x_1, x_2)\} \subset \mathbf{Z}^2$ denote a set of representatives for $\mathbf{Z}^2 / \rho_\ell \mathbf{Z}^2$. We have*

$$\mathcal{D}_{r,s}^\ell(\rho, v) = \text{sgn}(\det(\rho)) \sum_x \mathcal{B}_{r,s}^{L, -x_1}(\rho_\ell^{-1}(x + \pi_\ell v)). \quad (4.80)$$

Remark 4.18. One easily checks that the summand in (4.80) is independent of the choice of representative $x \in \mathbf{Z}^2$ for each class in $\mathbf{Z}^2 / \rho_\ell \mathbf{Z}^2$.

Proof. The map $(x, y) \mapsto z = \pi_\ell^{-1}x + \ell^{-1}\rho y$ induces a bijection between $\mathbf{Z}^2/\rho_\ell\mathbf{Z}^2 \times \mathbf{Z}^2/\ell\mathbf{Z}^2$ and $\pi_\ell^{-1}\mathbf{Z}^2/\rho\mathbf{Z}^2$. Furthermore, under this bijection

$$L(y) \equiv -x_1 \pmod{\ell} \iff z \in \mathbf{Z}^2.$$

The result follows immediately from the definitions (4.60) and (4.78). \square

From Theorem 4.10 and Lemma 4.17, we find:

Proposition 4.19. *We have*

$$\Psi_\ell(A_1, A_2)(P, v) = \operatorname{sgn}(\det(\rho)) \sum_{r=0}^d P_r(\rho) \sum_{x \in \mathbf{Z}^2/\rho_\ell\mathbf{Z}^2} \mathcal{B}_{1+r, 1+d-r}^{L, -x_1}(\rho_\ell^{-1}(x + \pi_\ell v)). \quad (4.81)$$

In the next section, we demonstrate an integrality property of the individual terms in the sum over x in (4.81) when $d = 0$. The integrality of Ψ_ℓ in general will follow by bootstrapping from this base case.

4.3.2 The case $d = 0$

The following ‘‘cyclotomic Dedekind sum’’ attached to a real number x will play an important role in our computations. Define

$$B_1^{\exp}(x, r) = \sum_{m=1}^{\ell} e\left(\frac{rm}{\ell}\right) \tilde{B}_1\left(\frac{x+m}{\ell}\right) \quad (4.82)$$

for any $x \in \mathbf{R}$ and $r \in \mathbf{F}_\ell^\times$. The periodic Bernoulli polynomial \tilde{B}_1 was defined in (4.5). We leave the proof of the following lemma as an exercise.

Lemma 4.20. *The value of the cyclotomic Dedekind sum is given by*

$$B_1^{\exp}(x, r) = \frac{e\left(\frac{-r[x]}{\ell}\right)}{e\left(\frac{r}{\ell}\right) - 1} + \frac{\delta_x}{2} e\left(-\frac{rx}{\ell}\right), \quad (4.83)$$

where $\delta_x = 1$ if $x \in \mathbf{Z}$ and $\delta_x = 0$ otherwise.

The following is the aforementioned integrality property of the individual terms in (4.81) when $d = 0$.

Proposition 4.21. *Let $x \in \mathbf{Q}^2$, $x \notin \mathbf{Z}^2$. The quantity $\mathcal{B}_{1,1}^{L,z}(x)$ lies in $\frac{1}{2}\mathbf{Z}[\frac{1}{\ell}]$, and lies in $\frac{1}{2}\mathbf{Z}$ if $\ell > 3$. Furthermore, these statements both hold without the factor $\frac{1}{2}$ if neither coordinate of x is an integer.*

Proof. This proof follows the argument of [11, Sect. 6.1]. We begin by relaxing the restricted summation. Since the map

$$y \mapsto \frac{1}{\ell} \sum_{k=0}^{\ell-1} e\left(\frac{kL(y)}{\ell}\right)$$

is the characteristic function of the kernel of L , we obtain

$$\mathcal{B}_{r,s}^{L,z}(x) = - \sum_{k=1}^{\ell-1} \sum_{y \in \mathbf{F}_\ell^2} e\left(\frac{k(L(y) - z)}{\ell}\right) \mathcal{B}_{r,s}\left(\frac{x+y}{\ell}\right). \quad (4.84)$$

Note that the term $k = 0$ cancels the leading term of $\mathcal{B}_{r,s}^{L,z}$ using the distribution relation for $\mathcal{B}_{r,s}$. Write $L\begin{pmatrix} y_1 \\ y_2 \end{pmatrix} = a_1 y_1 + a_2 y_2$. Specializing to $(r, s) = (1, 1)$, the sum (4.84) decomposes as

$$- \sum_{k=1}^{\ell-1} e\left(-\frac{kz}{\ell}\right) \sum_{y_1, y_2=1}^{\ell} \prod_{j=1}^2 e\left(\frac{k a_j y_j}{\ell}\right) \tilde{B}_1\left(\frac{x_j + y_j}{\ell}\right).$$

Since each a_j is non-zero modulo ℓ by assumption, we can use Lemma 4.20 twice to obtain

$$\begin{aligned} \mathcal{B}_{1,1}^{L,z}(x) &= - \sum_{k=1}^{\ell-1} e\left(-\frac{kz}{\ell}\right) \prod_{j=1}^2 \left(\frac{e\left(-\frac{k a_j [x_j]}{\ell}\right)}{e\left(\frac{k a_j}{\ell}\right) - 1} + \frac{\delta_{x_j}}{2} e\left(-\frac{k a_j x_j}{\ell}\right) \right) \\ &= - \operatorname{Tr}_{\mathbf{Q}(\mu_\ell)/\mathbf{Q}} \left(\frac{e\left(\frac{-z-L([x])}{\ell}\right)}{\left(e\left(\frac{a_1}{\ell}\right) - 1\right)\left(e\left(\frac{a_2}{\ell}\right) - 1\right)} \right) \end{aligned} \quad (4.85)$$

$$- \frac{\delta_{x_2}}{2} \operatorname{Tr}_{\mathbf{Q}(\mu_\ell)/\mathbf{Q}} \left(\frac{e\left(\frac{-z-L([x])}{\ell}\right)}{e\left(\frac{a_1}{\ell}\right) - 1} \right) - \frac{\delta_{x_1}}{2} \operatorname{Tr}_{\mathbf{Q}(\mu_\ell)/\mathbf{Q}} \left(\frac{e\left(\frac{-z-L([x])}{\ell}\right)}{e\left(\frac{a_2}{\ell}\right) - 1} \right). \quad (4.86)$$

Note that there is no “fourth term” since $x \notin \mathbf{Z}^2$, so $\delta_{x_1} \delta_{x_2} = 0$. The traces in (4.85) and (4.86) clearly lie in $\mathbf{Z}[\frac{1}{\ell}]$. Furthermore, since $\zeta_\ell - 1$ has ℓ -adic valuation $1/(\ell - 1)$ for any primitive ℓ -th root of unity ζ_ℓ , the expression in (4.85) has denominator at most $\ell^{\frac{2}{\ell-1}}$ and the traces in (4.86) have denominator at most $\ell^{\frac{1}{\ell-1}}$. \square

4.3.3 Proof of Theorem 4.15

We are now ready to complete the proof of Theorem 4.15. If

$$\mathcal{C} = ([A_1] - [A_2]) \otimes \varphi_{1,v} \in I_\Gamma \otimes \mathcal{M}_\ell^\vee$$

with $A_1^{-1}v = A_2^{-1}v$, then the desired result

$$\langle [\Psi_\ell], [\mathcal{C}] \rangle = \Psi_\ell(A_1, A_2)(1, v) \in \mathbf{Z}[\frac{1}{\ell}]$$

follows, up to a factor of $1/2$, from Propositions 4.19 and 4.21. We will first show how to deal with the nuisance factor $1/2$. Then we will show how to generalize from $P = 1$ to general P . The first problem is dealt with using the following lemmas; the main idea is to represent any class in $H_1(\Gamma_0(\ell), \mathcal{M}_\ell^\vee)_{\text{int}}$ with a cycle such that in all applications of Proposition 4.21, none of the coordinates of x is integral.

Lemma 4.22. *Any class $[C] \in H_1(\Gamma, \mathcal{M}_\ell^\vee)_{\text{int}}$ has a representative \mathcal{C} that can be expressed as a linear combination of cycles of the form*

$$([1] - [\gamma]) \otimes \varphi_{P,v} \quad (4.87)$$

satisfying conditions (4.38) and (4.39), and such that $\pi_\ell v \in \mathcal{V}$ has neither coordinate integral.

Proof. By definition, a class $[C] \in H_1(\Gamma, \mathcal{M}_\ell^\vee)_{\text{int}}$ has a representative \mathcal{C} that may be expressed as a linear combination of cycles

$$([A_1] - [A_2]) \otimes \varphi_{P,v}$$

satisfying (4.38) and (4.39). This cycle is equivalent modulo the action of $\Gamma_0(\ell)$ to

$$([1] - [\gamma]) \otimes \varphi_{A_1^t P, A_1^{-1} v} \quad (4.88)$$

where $\gamma = A_1^{-1} A_2$. The element (4.88) still satisfies (4.38) and (4.39). Let us therefore relabel $(A_1^t P, A_1^{-1} v)$ as (P, v) , with γ satisfying $\gamma^t P = P$ and $\gamma^{-1} v = v$. The lemma is proven unless one of the coordinates of $\pi_\ell v$ is integral. To handle this situation we use a trick. Note that for any $g \in \Gamma_0(\ell)$, we have

$$([1] - [g]) \otimes \varphi_{P,v} = ([\gamma] - [\gamma g]) \otimes \varphi_{P,v}$$

in $(I_{\Gamma_0(\ell)} \otimes \mathcal{M}_\ell^\vee)_{\Gamma_0(\ell)}$, and hence

$$\begin{aligned} ([1] - [\gamma]) \otimes \varphi_{P,v} &= ([g] - [\gamma g]) \otimes \varphi_{P,v} \\ &= [1] - [g^{-1} \gamma g] \otimes \varphi_{g^t P, g^{-1} v}. \end{aligned} \quad (4.89)$$

The right side of (4.89) satisfies (4.38) and (4.39), and we will show that it is possible to choose g such that $g^{-1} v$ has neither coordinate integral. We are given that $v \in \mathcal{V}_\ell$, so either

ℓv_1 or v_2 is not integral. If v_2 is not integral, then $g = \begin{pmatrix} 1 & 0 \\ 1 & 1 \end{pmatrix}$ has the desired property, and

if ℓv_1 is not integral, then $g = \begin{pmatrix} 1 & 0 \\ \ell & 1 \end{pmatrix}$ has the desired property. \square

Lemma 4.23. *Consider a cycle*

$$([1] - [\gamma]) \otimes \varphi_{P,v}$$

satisfying conditions (4.38) and (4.39), and such that $\pi_\ell v \in \mathcal{V}$ has neither coordinate integral. Then neither coordinate of y is integral for all $y \in \rho_\ell^{-1}(\mathbf{Z}^2 + \pi_\ell v)$.

Here, as usual, ρ_ℓ denotes the matrix containing the first columns of the matrices 1 and $\pi_\ell \gamma \pi_\ell^{-1}$.

Proof. If $\gamma = \begin{pmatrix} a & b \\ c\ell & d \end{pmatrix}$, then $\rho_\ell = \begin{pmatrix} 1 & a \\ 0 & c \end{pmatrix}$. We have $\pi_\ell v \in \rho_\ell(y) + \mathbf{Z}^2$. In particular, $v_2 \equiv cy_2$

(mod \mathbf{Z}), so $y_2 \notin \mathbf{Z}$. Write $\gamma' = \begin{pmatrix} a & b\ell \\ c & d \end{pmatrix} = \pi_\ell \gamma \pi_\ell^{-1}$. Since $\gamma'(\pi_\ell v) \equiv \pi_\ell v$ (mod \mathbf{Z}^2), it follows

that $\pi_\ell v \in (\gamma')^{-1} \rho_\ell(v) + \mathbf{Z}^2$. Since $(\gamma')^{-1} \rho_\ell = \begin{pmatrix} d & 1 \\ -c & 0 \end{pmatrix}$, we find $v_2 \equiv -cy_1$ (mod \mathbf{Z}), so

$y_1 \notin \mathbf{Z}$. \square

We can now prove Theorem 4.3.3 in the case $P = 1$. Lemmas 4.22 and 4.23 allow us to consider cycles of the form $\mathcal{C} = [1] - [\gamma] \otimes \varphi_{1,v}$ such that for all $y \in \rho_\ell^{-1}(\mathbf{Z}^2 + \pi_\ell v)$, neither coordinate of y is integral. Propositions 4.19 and 4.21 then yield:

Proposition 4.24. *Given a cycle*

$$\mathcal{C} = ([A_1] - [A_2]) \otimes \varphi_{1,v} \in I_\Gamma \otimes \mathcal{M}_\ell^\vee,$$

we have that

$$\langle [\Psi_\ell], [\mathcal{C}] \rangle = \Psi_\ell(A_1, A_2)(1, v)$$

lies in $\mathbf{Z}[\frac{1}{\ell}]$, and in fact lies in \mathbf{Z} if $\ell > 3$.

Now we move on to the generalization from $P = 1$ to P of larger degree. We will show that for $[\mathcal{C}] \in H_1(\Gamma, \mathcal{M}_\ell^\vee)_{\text{int}}$, the value $\langle [\Psi_\ell], [\mathcal{C}] \rangle$ lies in \mathbf{Z}_p for each prime $p \neq \ell$.

Proposition 4.25. *Let $x \in \mathbf{Q}^2$ and let $p \neq \ell$ be a prime number. Let $0 \leq r \leq d$ be integers. There exists an integer ε depending only on d, ℓ and the denominator of x , such that for all integers $M \geq \varepsilon$ we have the following congruence between rational numbers:*

$$p^{Md} r!(d-r)! \mathcal{B}_{1+r,1+d-r}^{L,z} \left(\frac{x}{p^M} \right) \equiv \mathcal{B}_{1,1}^{L,z} \left(\frac{x}{p^M} \right) \frac{x_1^r x_2^{d-r}}{\ell^d} \pmod{p^{M-\varepsilon} \mathbf{Z}_p}. \quad (4.90)$$

Before proving Proposition 4.25, we show how it enables the proof of Theorem 4.15.

Proof of Theorem 4.15. Lemmas 4.22 and 4.23 allow us to consider cycles of the form $\mathcal{C} = [1] - [\gamma] \otimes \varphi_{P,v}$ satisfying (4.38) and (4.39), such that for all $y \in \rho_\ell^{-1}(\mathbf{Z}^2 + \pi_\ell v)$, neither coordinate of y is integral. We recall Proposition 4.19:

$$\begin{aligned} \langle [\Psi_\ell], [\mathcal{C}] \rangle &= \Psi_\ell(1, \gamma)(P, v) \\ &= \text{sgn}(\det(\rho)) \sum_{r=0}^d P_r(\rho) \sum_{x \in \mathbf{Z}^2 / \rho_\ell \mathbf{Z}^2} \mathcal{B}_{1+r,1+d-r}^{L,-x_1}(\rho_\ell^{-1}(x + \pi_\ell v)). \end{aligned} \quad (4.91)$$

For each x in the sum in (4.91) we let $y = \rho_\ell^{-1}(x + \pi_\ell v)$ and note that y has the property

$$\frac{1}{\ell} \rho(y) \in v + \frac{1}{\ell} \mathbf{Z} \oplus \mathbf{Z}^{n-1}. \quad (4.92)$$

Fix a prime $p \neq \ell$. For each y we let ε be as in Proposition 4.25 and fix a positive integer $M > \varepsilon + \text{ord}_p(d!)$. Applying the distribution relation (4.79) we replace the term $\mathcal{B}_{1+r,1+d-r}^{L,-x_1}(y)$ in (4.91) with

$$p^{Md} \sum_{k \in (\ell \mathbf{Z} / \ell p^M \mathbf{Z})^2} \mathcal{B}_{1+r,1+d-r}^{L,z} \left(\frac{y+k}{p^M} \right), \quad (4.93)$$

where $z \equiv -p^{-M} x_1 \pmod{\ell}$. By Proposition 4.25 and the choice of M , the quantity in (4.93) is congruent modulo \mathbf{Z}_p to

$$\frac{1}{r!(d-r)!} \sum_{k \in (\ell \mathbf{Z} / \ell p^M \mathbf{Z})^2} \mathcal{B}_{1,1}^{L,z} \left(\frac{y+k}{p^M} \right) \frac{(y_1+k_1)^r (y_2+k_2)^{d-r}}{\ell^d}.$$

Plugging this expression into (4.91), we note that each coefficient $\frac{P_r(\rho)}{r!(d-r)!\ell^d}$ in lies in \mathbf{Z}_p , and hence $\Psi_\ell(1, \gamma)(P, v)$ is congruent modulo \mathbf{Z}_p to

$$\pm \sum_x \sum_{k \in (\ell\mathbf{Z}/\ell p^M\mathbf{Z})^2} \mathcal{B}_{1,1}^{L,z} \left(\frac{y+k}{p^M} \right) \sum_{r=0}^d \frac{P_r(\sigma)}{r!(d-r)!} \cdot \frac{(y_1+k_1)^r (y_2+k_2)^{d-r}}{\ell^d}. \quad (4.94)$$

By the definition (4.47), the sum over r in (4.94) is equal to $P\left(\frac{\rho(y+k)}{\ell}\right)$, which by (4.92) and the property

$$P(v + \frac{1}{\ell}\mathbf{Z} \oplus \mathbf{Z}) \subset \mathbf{Z}\left[\frac{1}{\ell}\right]$$

given in (4.39) lies in \mathbf{Z}_p . Therefore, by Proposition 4.21, each term in (4.94) lies in \mathbf{Z}_p , and the theorem is proven. \square

Proof of Proposition 4.25. As in the classical Kubota–Leopoldt construction of p -adic L -functions over \mathbf{Q} , the proof relies on the fact that the Bernoulli polynomial $B_k(x)$ begins

$$B_k(x) = x^k - \frac{k}{2}x^{k-1} + \dots. \quad (4.95)$$

We recall equation (4.84):

$$\mathcal{B}_{1+r,1+d-r}^{L,z}(x) = - \sum_{k=1}^{\ell-1} \sum_{y \in \mathbf{F}_\ell^2} e\left(\frac{k(L(y)-z)}{\ell}\right) \mathcal{B}_{1+r,1+d-r}\left(\frac{x+y}{\ell}\right). \quad (4.96)$$

At the expense of altering z , we may translate x by an element of $p^M\mathbf{Z}^n$ and assume that x/p^M belongs to $[0, 1)^2$. Furthermore, for each class in \mathbf{F}_ℓ^2 we choose the representative $y \in \mathbf{Z}^2$ with $0 \leq y_j \leq \ell - 1$. Suppose that $r \geq 1$. Equation (4.95) yields

$$p^{Mr} B_{1+r}\left(\frac{\frac{x_1}{p^M} + y_1}{\ell}\right) \equiv p^{-M} \left(\frac{x_1}{\ell}\right)^{1+r} + (1+r) \left(\frac{x_1}{\ell}\right)^r \left(\frac{y_1}{\ell} - \frac{1}{2}\right) \pmod{p^{M-\varepsilon}\mathbf{Z}_p},$$

where ε depends only on r , ℓ and the power of p in the denominator of x_1 . Write $L\begin{pmatrix} y_1 \\ y_2 \end{pmatrix} = a_1 y_1 + a_2 y_2$, and multiply the previous congruence by $e\left(\frac{ka_1 y_1}{\ell}\right)$. Summing over all $0 \leq y_1 \leq \ell - 1$, the leading term of the right side vanishes and we obtain

$$\begin{aligned} p^{Mr} \sum_{y_1 \in \mathbf{F}_\ell} e\left(\frac{ka_1 y_1}{\ell}\right) \tilde{B}_{1+r}\left(\frac{\frac{x_1}{p^M} + y_1}{\ell}\right) &\equiv \\ (1+r) \left(\frac{x_1}{\ell}\right)^r \sum_{y_1 \in \mathbf{F}_\ell} e\left(\frac{ka_1 y_1}{\ell}\right) \tilde{B}_1\left(\frac{\frac{x_1}{p^M} + y_1}{\ell}\right) &\pmod{p^{M-\varepsilon}\mathbf{Z}_p[\zeta_\ell]}, \end{aligned} \quad (4.97)$$

with both sides lying in $p^{-\varepsilon}\mathbf{Z}_p[\zeta_\ell]$. Of course, if $r = 0$ then this congruence holds tautologically. Let us now multiply this congruence by the analogous one with r replaced by $d - r$ and (x_1, y_1) by (x_2, y_2) .

Multiplying by $-e(-kz/\ell)$ and summing over $k = 1, \dots, \ell - 1$ gives the desired result by using (4.96) on both sides of the congruence (after dividing by $(1+r)(1+d-r)$ and increasing ε accordingly). \square

4.4 Applications to Stark's conjecture

In this section we interpret the cocycle Ψ_ℓ in terms of p -adic measures and use this perspective to prove the existence of p -adic partial zeta functions of real quadratic fields. We then use this formalism to present a conjectural formula for Stark units in the case TR_p .

4.4.1 A cocycle of measures

Fix a prime $p \neq \ell$. Let A be a subgroup of \mathbf{Q}_p that is bounded in the p -adic topology (i.e. $A \subset \frac{1}{p^n}\mathbf{Z}_p$ for some integer n). Let \mathbf{Y} be a compact open subset of \mathbf{Q}_p^2 . We define an A -valued measure on \mathbf{Y} to be an assignment $\mu: U \mapsto \mu(U) \in A$ for each compact open subset $U \subset \mathbf{Y}$ such that $\mu(U \cup V) = \mu(U) + \mu(V)$ for disjoint U and V . If E is a finite extension of \mathbf{Q}_p and $f: \mathbf{Y} \rightarrow E$ is a continuous function, then we can define the integral of f with respect to μ via the usual Riemann sum process as follows. Since \mathbf{Y} is a compact open subset of \mathbf{Q}_p^2 , it can be written for n large enough as a disjoint union

$$\mathbf{Y} = \bigsqcup_{i=1}^{y_n} a_{i,n} + p^n \mathbf{Z}_p^2.$$

Define

$$\int_{\mathbf{Y}} f(x) d\mu(x) := \lim_{n \rightarrow \infty} \sum_{i=1}^{y_n} f(a_i) \mu(a_i + p^n \mathbf{Z}_p^2) \in E. \quad (4.98)$$

Exercise: Prove that the limit in (4.98) converges by showing that the sequence of partial sums is Cauchy, and show that the limit does not depend on the “test points” $a_{i,n} \in \mathbf{Y}$ chosen in the open sets $a_{i,n} + p^n \mathbf{Z}_p^2$.

Let $\mathbf{M}(\mathbf{Y})$ denote the \mathbf{Q}_p -vector space of measures on \mathbf{Y} that take values in some bounded subgroup of \mathbf{Q}_p . Given a $\mu \in \mathbf{M}(\mathbf{Y})$ and a matrix $\gamma \in \mathbf{SL}_2(\mathbf{Z}_p)$, we obtain a measure $\gamma\mu \in \mathbf{M}(\gamma\mathbf{Y})$ via $(\gamma\mu)(U) := \mu(\gamma^{-1}U)$.

Given $A_1, A_2 \in \Gamma_0(\ell)$ and $v \in \mathcal{V}_\ell$, we define a $\frac{1}{2}\mathbf{Z}[\frac{1}{\ell}]$ -valued measure $\mu_\ell(A_1, A_2)(v)$ on

$$\mathbf{Y}_v := v + \mathbf{Z}_p^2 \subset \mathbf{Q}_p^2$$

as follows. Let ρ denote the matrix whose columns are the first columns of A_1, A_2 . If $\det(\rho) = 0$, then $\mu_\ell(A_1, A_2)(v)$ is the 0 measure. Suppose that $\det(\rho) \neq 0$. A vector $a \in \mathbf{Z}^2$ and a nonnegative integer r give rise to the compact open subset

$$a + p^r \mathbf{Z}_p^2 \subset \mathbf{Z}_p^2.$$

These sets form a basis of compact open subsets of \mathbf{Z}_p^2 , and hence their translates by v form a basis of compact open subsets of \mathbf{Y}_v . We define μ_ℓ by applying Ψ_ℓ with the constant polynomial $P = 1$:

$$\mu(A_1, A_2)(v)(v + a + p^r \mathbf{Z}_p^2) = \Psi_\ell(A_1, A_2) \left(1, \frac{v+a}{p^r} \right) \in \frac{1}{2}\mathbf{Z}[\frac{1}{\ell}] \subset \frac{1}{2}\mathbf{Z}_p. \quad (4.99)$$

It is easily checked that this assignment is well-defined, and that the distribution relation for Ψ_ℓ implies the necessary additivity property for μ_ℓ .

Let $\mathcal{M}_{\ell,p}$ denote the space of functions that assigns to each $v \in \mathcal{V}_\ell$ a measure $\alpha(v) \in \mathbf{M}(\mathbf{Y}_v)$, such that the distribution relation

$$\sum_{w \in (\frac{1}{N}\mathbf{Z}/\mathbf{Z})^2} \alpha\left(\frac{v}{N} + w\right) = \alpha(v)$$

is satisfied for each positive integer N relatively prime to p . Exercise: show that $\mu_\ell(A_1, A_2) \in \mathcal{M}_{\ell,p}$.

Proposition 4.26. *The function $\mu_\ell : \Gamma_0(\ell)^2 \rightarrow \mathcal{M}_{\ell,p}$ is a homogeneous 1-cocycle.*

Proposition 4.26 follows directly from the fact that Ψ_ℓ is a cocycle; we leave the proof as an exercise. The following theorem shows that the cocycle Ψ_ℓ can be recovered from the cocycle of measures μ_ℓ ; in other words, the cocycle Ψ_ℓ specialized to $P = 1$ determines its value on all $P \in \mathcal{P}$.

Theorem 4.27. *For any $P \in \mathcal{P}$ we have*

$$\Psi_\ell(A_1, A_2)(P, v) = \int_{\mathbf{Y}_v} P(x) d\mu_\ell(A_1, A_2)(v)(x). \quad (4.100)$$

Proof. It suffices to prove the result when P is homogeneous of degree d . We follow closely the proof of Theorem 4.15. It was shown there (see (4.94)) that there exists an integer ε such that for each positive integer $M \geq \varepsilon$, the quantity $\Psi_\ell(A_1, A_2)(P, v)$ is congruent to

$$\pm \sum_x \sum_{k \in (\ell\mathbf{Z}/\ell p^M\mathbf{Z})^2} \mathcal{B}_{1,1}^{L, -p^{-M}x_1} \left(\frac{y+k}{p^M} \right) P \left(\frac{\rho(y+k)}{\ell} \right) \quad (4.101)$$

modulo $p^{M-\varepsilon}\mathbf{Z}_p$. Here x sums over representatives in \mathbf{Z}^2 for $\mathbf{Z}^2/\rho_\ell\mathbf{Z}^2$ and $y = \rho_\ell^{-1}x + \rho^{-1}\ell v$. The \pm sign is $\text{sgn}(\det(\rho))$. The expression (4.101) is simplified with a change of variables. Let j run over arbitrary representatives for $\mathbf{Z}^2/p^M\mathbf{Z}^2$ (i.e. not necessarily divisible by ℓ) such that $j \equiv k \pmod{p^M}$, and let $u = x + \rho_\ell(j)$; the expression (4.101) is congruent modulo p^M to:

$$\pm \sum_{u \in \mathbf{Z}^2/p^M\rho_\ell\mathbf{Z}^2} \mathcal{B}_{1,1}^{L, -p^{-M}u_1} \left(\frac{\rho_\ell^{-1}(u) + \sigma^{-1}\ell v}{p^M} \right) P(\pi_\ell^{-1}u + v). \quad (4.102)$$

Let us meanwhile evaluate the Riemann sums approximating the integral on the right side of (4.100). There is a δ , depending on the powers of p in the denominator of $P(v)$, such that for M large we have

$$\begin{aligned} \int_{\mathbf{Y}_v} P(x) d\mu(x) &\equiv \sum_{j \in (\mathbf{Z}/p^M\mathbf{Z})^2} P(v+j) \mu(v+j+p^M\mathbf{Z}_p^2) \pmod{p^{M-\delta}\mathbf{Z}_p} \\ &= \sum_{j \in (\mathbf{Z}/p^M\mathbf{Z})^2} P(v+j) \mathcal{D}_{1,1}^\ell \left(\rho, \frac{v+j}{p^M} \right). \end{aligned} \quad (4.103)$$

As j runs over $(\mathbf{Z}/p^M\mathbf{Z})^2$, let k run over representatives for $\mathbf{Z}^2/p^M\mathbf{Z}^2$ such that $k \equiv \pi_\ell j$. An argument similar to the proof of Lemma 4.17 shows that

$$\mathcal{D}_{1,1}^\ell \left(\rho, \frac{v+j}{p^M} \right) = \sum_{z \in \mathbf{Z}^2/\rho_\ell \mathbf{Z}^2} \mathcal{B}_{1,1}^{L,-z_1-p^{-M}k} \left(\rho_\ell^{-1}(z) + \frac{\rho_\ell^{-1}(k) + \rho^{-1}\ell v}{p^M} \right).$$

Substituting this expression into (4.103) and using the change of variables $u = p^M z + k$ shows that the integral is congruent to (4.102) modulo $p^{M-\max\{\varepsilon,\delta\}}$. Taking the limit as $M \rightarrow \infty$, the result follows. \square

As before, it is convenient to express our results in terms of the natural pairings between cohomology and homology. Let $\mathcal{M}_{\ell,p}^\vee$ denote the \mathbf{Z}_p -dual of $\mathcal{M}_{\ell,p}$, which is endowed with the dual action of $\Gamma_0(\ell)$. As in Section 4.1.5, there is a natural pairing

$$H^1(\Gamma_0(\ell), \mathcal{M}_{\ell,p}) \times H_1(\Gamma_0(\ell), \mathcal{M}_{\ell,p}^\vee) \rightarrow \mathbf{Z}_p$$

given by

$$\langle [\mu], \left[\sum ([A_1] - [A_2]) \otimes \varphi \right] \rangle = \sum \varphi(\mu(A_1, A_2)).$$

An element $v \in \mathcal{V}_\ell$ and a continuous function $f: \mathbf{Y}_v \rightarrow \mathbf{Z}_p$ and a give rise to an element $\varphi_{f,v} \in \mathcal{M}_{\ell,p}^\vee$ defined by

$$\varphi_{f,v}(\alpha) = \int_{\mathbf{Y}_v} f(x) d\mu(x) \quad \text{where } \mu = \alpha(v). \quad (4.104)$$

If a polynomial $P \in \mathcal{P}$ and $v \in \mathcal{V}_\ell$ satisfy the integrality condition (4.39), then P viewed as a continuous function on \mathbf{Y}_v has image contained in \mathbf{Z}_p . Combined with (4.104) this induces a natural map

$$\begin{aligned} H_1(\Gamma_0(\ell), \mathcal{M}_{\ell,p}^\vee)_{\text{int}} &\longrightarrow H_1(\Gamma_0(\ell), \mathcal{M}_{\ell,p}^\vee). \\ ([A_1] - [A_2]) \otimes \varphi_{P,v} &\longmapsto ([A_1] - [A_2]) \otimes \varphi_{P,v}. \end{aligned} \quad (4.105)$$

Theorem 4.27 implies that for $[C] \in H_1(\Gamma_0(\ell), \mathcal{M}_{\ell,p}^\vee)_{\text{int}}$, we have

$$\langle [\Psi_\ell], [C] \rangle = \langle [\mu_\ell], [\mathcal{D}] \rangle, \quad (4.106)$$

where $[\mathcal{D}]$ denotes the image of $[C]$ under (4.105).

4.4.2 p -adic zeta functions

We now return to the setting of a real quadratic field F . Let \mathfrak{a} be an integral ideal of F and let \mathfrak{c} be an ideal of norm ℓ such that $(\mathfrak{a}, \mathfrak{c}) = 1$. Let S and T be finite sets of primes of F as before, and assume that S contains all the primes of F lying above p . We will use the p -adic measures defined above to construct the p -adic zeta functions associated to the extension K/F .

Theorem 4.28. *Fix $K/F, S, T$, and p as above. Let $\sigma \in G = \text{Gal}(K/F)$. There exists a unique \mathbf{Z}_p -valued analytic function $\zeta_{K/F,S,T,p}(\sigma, s)$ of the p -adic variable $s \in \mathcal{W}$ such that*

$$\zeta_{K/F,S,T,p}(\sigma, 1-r) = \zeta_{K/F,S,T}(\sigma, 1-r). \quad (4.107)$$

for all positive integers r .

The special values of the classical zeta function on the right side of (4.107) lie in $\mathbf{Z}[\frac{1}{\ell}] \subset \mathbf{Z}_p$ by Theorem 4.6.

Proof. First we note that it suffices to consider the case where \mathfrak{f} is divisible by all primes of F above p . Indeed, if we let \mathfrak{g} denote the least common multiple of \mathfrak{f} and the primes dividing p , then the p -adic zeta functions for K/F and $K_{\mathfrak{g}}/F$ are related as follows:

$$\zeta_{K/F,S,T,p}(\sigma, s) = \sum_{\substack{\tau \in \text{Gal}(K_{\mathfrak{g}}/F) \\ \tau|_K = \sigma}} \zeta_{K_{\mathfrak{g}}/F,S,T,p}(\tau, s). \quad (4.108)$$

The analogous equation for the classical partial zeta functions follows from the condition that S contains all the primes above p .

Therefore, suppose that \mathfrak{f} is divisible by all primes of F above p . Fix \mathfrak{a} relatively prime to \mathfrak{f} and p such that $\sigma_{\mathfrak{a}} = \sigma$. Let P, v , and γ be as in (4.40)–(4.41). For any $x \in \mathbf{Z}^n$ the quantity $P(v+x)$ is the norm of an integral ideal of F relatively prime to \mathfrak{f} . Since \mathfrak{f} is divisible by all the primes above p , this quantity is an integer relatively prime to p . By the continuity of P , we find that

$$P(v+x) \in \mathbf{Z}_p^{\times}$$

for all $x \in \mathbf{Z}_p^2$.

We define a p -adic analytic \mathbf{Z}_p -valued function on $\mathbf{Y}_v \times \mathcal{W}$:

$$f(x, s) = P(x)^{-s}.$$

The function f in turn yields a p -adic analytic family of cycles

$$\mathcal{D}_s := ([1] - [\gamma]) \otimes \varphi_{f(-,s),v}$$

giving classes $[\mathcal{D}_s] \in H_1(\Gamma_0(\ell), \mathcal{M}_{\ell,p}^{\vee})$. We define an analytic function $\zeta_{K/F,S,T,p}(\sigma, s) : \mathcal{W} \rightarrow \mathbf{Z}_p$ by:

$$\zeta_{K/F,S,T,p}(\sigma, s) = \langle [\mu_{\ell}], [\mathcal{D}_s] \rangle \quad (4.109)$$

$$= \int_{\mathbf{Y}_v} P(x)^{-s} d\mu(A_1, A_2)(v)(x). \quad (4.110)$$

If r is a positive integer, then the image of $\mathcal{C}_{P,v,r} = ([A_1] - [A_2]) \otimes \varphi_{P^{r-1},v}$ under (4.105) is \mathcal{D}_{1-r} . Therefore, we find from (4.106):

$$\begin{aligned} \zeta_{K/F,S,T,p}(\sigma, 1-r) &= \langle [\mu_{\ell}], [\mathcal{D}_{1-r}] \rangle \\ &= \langle [\Psi_{\ell}], [\mathcal{C}_{P,v,r}] \rangle \\ &= \zeta_{K/F,S,T}(\sigma, 1-r). \end{aligned}$$

This is the desired interpolation property of our p -adic zeta function. \square

Note that the meromorphic function $\zeta_{K/F,S,p}: \mathcal{W} \rightarrow \mathbf{Q}_p$ mentioned in (2.5) can be defined by choosing the set $T = \{\mathfrak{c}\}$ such that \mathfrak{c} splits completely in K , and letting

$$\zeta_{K/F,S,p}(\sigma, s) = \frac{\zeta_{K/F,S,T,p}(\sigma, s)}{(1 - N\mathfrak{c}^{1-s})}. \quad (4.111)$$

Exercise: Show that $\zeta_{K/F,S,p}$ has the desired interpolation property (2.6) and that (4.111) is independent of the choice of T .

4.4.3 A conjectural formula for Stark units

We finally come to the climax of our discussion of the Eisenstein cocycle—a conjectural formula for Stark units in case TR_p . Recall that K is the narrow ray class field of conductor \mathfrak{f} of F . To simplify notation, we assume that the rational prime p is inert in F , and satisfies $p \equiv 1 \pmod{\mathfrak{f}}$. This implies that p splits completely in K . The general case—in which p is replaced by an arbitrary prime ideal \mathfrak{p} and K is replaced by its maximal subfield in which \mathfrak{p} splits—is similar, but notationally more complicated.

Denote by $\mathbf{X} := \mathbf{Z}_p^2 - p\mathbf{Z}_p^2$ the set of *primitive vectors* in \mathbf{Z}_p^2 .

Proposition 4.29. *With notation as above, we have*

$$\zeta_{K/F,S,T,p}(\sigma_{\mathfrak{a}}, s) = \int_{\mathbf{X}} P(x)^{-s} d\mu_{\ell}(1, \gamma)(v)(x). \quad (4.112)$$

Proof. It is possible to prove this directly from our construction of $\zeta_{K/F,S,T,p}(\sigma_{\mathfrak{a}}, s)$ using (4.108). However, we sketch a shorter argument. Let $R = S - \{p\}$. Since p splits completely in K , we have

$$\zeta_{K/F,S,T}(\sigma_{\mathfrak{a}}, s) = \zeta_{K/F,R,T}(\sigma_{\mathfrak{a}}, s)(1 - p^{-2s}) \quad (4.113)$$

for $s \in \mathbf{C}$. Let $s = 1 - r$, with r a positive integer. We will express the zeta value in (4.113) as an integral against the measure μ using Theorems 4.16 and 4.27. Note that $\mathbf{Y}_v = \mathbf{Z}_p^2$ since $(\mathfrak{f}, p) = 1$. We have:

$$\zeta_{K/F,R,T}(\sigma_{\mathfrak{a}}, s) = \int_{\mathbf{Z}_p^2} P(x)^{-s} d\mu_{\ell}(1, \gamma)(v)(x) \quad (4.114)$$

and

$$\begin{aligned} p^{-2s} \zeta_{K/F,R,T}(\sigma_{\mathfrak{a}}, s) &= \int_{\mathbf{Z}_p^2} P(px)^{-s} d\mu_{\ell}(1, \gamma)(v)(x) \\ &= \int_{p\mathbf{Z}_p^2} P(x)^{-s} d\mu_{\ell}(1, \gamma)(pv)(x) \\ &= \int_{p\mathbf{Z}_p^2} P(x)^{-s} d\mu_{\ell}(1, \gamma)(v)(x). \end{aligned} \quad (4.115)$$

The last equality uses the fact that $pv \equiv v \pmod{\mathbf{Z}^2}$, which holds since $p \equiv 1 \pmod{\mathfrak{f}}$. Combining (4.113)–(4.115) we find

$$\zeta_{K/F,S,T}(\sigma_a, s) = \int_{\mathbf{X}} P(x)^{-s} d\mu_\ell(1, \gamma)(v)(x). \quad (4.116)$$

Now the left and right sides of (4.112) are continuous functions on \mathcal{W} that agree with the left and right sides of (4.116) on the dense set of $s = 1 - r$, for positive integers r . Therefore they agree as functions on \mathcal{W} . \square

Note that by specializing (4.112) to $s = 0$, one finds that $\mu(1, \gamma)(v)$ has total measure 0 when restricted to \mathbf{X} :

$$\mu(1, \gamma)(v)(\mathbf{X}) = 0. \quad (4.117)$$

(This is easy to prove directly as well.) Writing (4.112) using the definition of P , we have:

$$\zeta_{K/F,S,T,p}(\sigma_a, s) = N\mathfrak{a}^{-s} \int_{\mathbf{X}} N_{F_p/\mathbf{Q}_p}(x_1w_1 + x_2w_2)^{-s} d\mu_\ell(1, \gamma)(v)(x).$$

Taking the derivative with respect to s and evaluating at $s = 0$, we obtain

$$\zeta'_{K/F,S,T,p}(\sigma_a, 0) = - \int_{\mathbf{X}} \log_p N_{F_p/\mathbf{Q}_p}(x_1w_1 + x_2w_2) d\mu_\ell(1, \gamma)(v)(x). \quad (4.118)$$

Let us fix a prime \mathfrak{P} of K above p . Gross's Conjecture 2.3 states that the left side of (4.118) is equal to $-\log_p N_{K_{\mathfrak{P}}/\mathbf{Q}_p}(u_T^{\sigma_a})$, where u_T is the Brumer–Stark–Tate unit associated to the data $(K/F, S, T, p, \mathfrak{P})$:

$$-\log_p N_{K_{\mathfrak{P}}/\mathbf{Q}_p}(u_T^{\sigma_a}) \stackrel{?}{=} - \int_{\mathbf{X}} \log_p N_{F_p/\mathbf{Q}_p}(x_1w_1 + x_2w_2) d\mu_\ell(1, \gamma)(v)(x). \quad (4.119)$$

It is natural to try to refine Gross's conjecture by simply removing the norms from (4.119). We arrive at:

Conjecture 4.30 (Logarithmic form). *We have*

$$\log_p(u_T^{\sigma_a}) = \int_{\mathbf{X}} \log_p(x_1w_1 + x_2w_2) d\mu_\ell(1, \gamma)(v)(x) \in \mathcal{O}_{F,p}.$$

Here $\mathcal{O}_{F,p}$ denotes the p -adic completion of \mathcal{O}_F , and $\log_p : F_p^\times \rightarrow \mathcal{O}_{F,p}$ is the Iwasawa branch of the p -adic logarithm ($\log_p(p) = 0$). The p -unit $u_T^{\sigma_a}$ is viewed as an element of F_p^\times via $u_T^{\sigma_a} \in K \subset K_{\mathfrak{P}} \cong F_p$.

Conjecture 4.30 is a true strengthening of Gross's Conjecture 2.3. Whereas Gross's formula for $u_T^{\sigma_a}$ has an ambiguity of multiplication by elements of norm 1 in $\mathcal{O}_{F,p}^\times$, Conjecture 4.30 only has a finite ambiguity of the roots of unity in $\mathcal{O}_{F,p}^\times$. (Recall that the p -adic valuation of $u_T^{\sigma_a}$ is specified by the Brumer–Stark–Tate conjecture.) Gross's conjecture is an equality in \mathbf{Z}_p , whereas Conjecture 4.30 is an equality in the quadratic unramified extension $\mathcal{O}_{F,p}$.

We now remove the logarithms from Conjecture 4.30 in order to present an *exact* formula for $u_T^{\sigma_a}$. Suppose that $\ell > 3$. Using Lemma 4.22, let us assume that neither coordinate of $v \in \mathcal{V}_\ell$ is integral. Following the proof of Lemma 4.23 one finds that neither coordinate of y is integral for $y \in \rho_\ell^{-1}(\mathbf{Z}^2 + \pi_\ell(\frac{v+a}{p^r}))$ when $a \in \mathbf{Z}^2$. By Propositions 4.19 and 4.21, it follows that

$$\mu(1, \gamma)(v)(v + a + p^r \mathbf{Z}_p^2) = \Psi_\ell(1, \gamma) \left(1, \frac{v + a}{p^r} \right) \in \mathbf{Z}, \tag{4.120}$$

i.e. $\mu(1, \gamma)(v)$ is a \mathbf{Z} -valued measure on \mathbf{X} .

Let \mathcal{O}_p be the ring of integers in an extension of \mathbf{Q}_p . Given a \mathbf{Z} -valued measure μ on \mathbf{X} and a continuous function $f: \mathbf{X} \rightarrow \mathcal{O}_p^\times$, there is a *multiplicative integral* defined as follows:

$$\int_{\mathbf{X}} f(x) d\mu(x) := \lim_{r \rightarrow \infty} \prod_{\substack{a \in (\mathbf{Z}/p^r \mathbf{Z})^2 \\ p \nmid a}} f(a)^{\mu(a + p^r \mathbf{Z}_p^2)} \in \mathcal{O}_p^\times.$$

Here $f(a)$ denotes the value of f at any test point in the open set $a + p^r \mathbf{Z}_p^2$. The multiplicative integral and the additive integral of (4.98) are related by the formula

$$\log_p \left(\int_{\mathbf{X}} f(x) d\mu(x) \right) = \int_{\mathbf{X}} \log_p(f(x)) d\mu(x).$$

The following conjecture refines Conjecture 4.30.

Conjecture 4.31 (Multiplicative form). *The element*

$$u_T(\mathbf{a}) := p^{\zeta_{K/F, R, T}(\sigma_{\mathbf{a}}, 0)} \int_{\mathbf{X}} (x_1 w_1 + x_2 w_2) d\mu_\ell(1, \gamma)(v)(x) \in F_p^\times \tag{4.121}$$

is an element of $K \subset K_{\mathfrak{p}} \cong F_p$. Furthermore, $u_T(\mathbf{a}) \in U_{p, S, T}(K)$, and we have the “Shimura Reciprocity Law:”

$$u_T(\mathbf{a})^{\sigma_{\mathbf{b}}} = u_T(\mathbf{a}\mathbf{b}).$$

Note that Conjecture 4.31 is self-contained and makes no reference to the conjectures of Brumer–Stark–Tate or Gross. In fact, the steps we used above to motivate the statement of Conjecture 4.31 can be easily reversed to show that this conjecture implies Conjectures 1.6 and 2.3, with $u_T^{\sigma_a} = u_T(\mathbf{a})$. We leave as an exercise the proof of the less obvious fact that Conjecture 4.31 implies Gross’s strong Conjecture 2.1 (see [11, Theorem 3.22]).

We conclude this chapter by formulating Conjecture 4.31 in terms of pairings between cohomology and homology. Let $\mathbf{M}(\mathbf{X}; \mathbf{Z})$ denote the Γ -module of \mathbf{Z} -valued measures on \mathbf{X} , and let $\mathbf{M}_0(\mathbf{X}; \mathbf{Z})$ denote the submodule of measures with total measure zero. Let $C(\mathbf{X})$ denote the Γ -module of continuous functions $\mathbf{X} \rightarrow \mathcal{O}_p^\times$, and let $C_0(\mathbf{X})$ denote the quotient of $C(\mathbf{X})$ by the subgroup of constant functions. There is a natural pairing:

$$\begin{aligned} \mathbf{M}_0(\mathbf{X}; \mathbf{Z}) \times C_0(\mathbf{X}) &\longrightarrow \mathcal{O}_p^\times \\ (\mu, f) &\longmapsto \int_{\mathbf{X}} f(x) d\mu(x). \end{aligned} \tag{4.122}$$

Let $H^1(\Gamma_0(\ell), \mathcal{M}_{\ell,p})_{\text{int}}$ denote the subgroup generated by classes $[\mu]$ such that

$$\mu(A_1, A_2)(v) \in \mathbf{M}_0(\mathbf{X}; \mathbf{Z})$$

whenever $A_1, A_2 \in \Gamma_0(\ell)$ and $v \in \mathcal{V}_\ell$ satisfy

$$A_1^{-1}v = A_2^{-1}v, \quad pv \equiv v \pmod{\mathbf{Z}}.$$

Our work above (including the application of Lemmas 4.22 and 4.23 to pass from $\frac{1}{2}\mathbf{Z}$ to \mathbf{Z}) shows that the cohomology class $[\mu_\ell]$ lies in $H^1(\Gamma_0(\ell), \mathcal{M}_{\ell,p})_{\text{int}}$.

Let $\mathcal{V}_{\ell,p} = \{v \in \mathcal{V}_\ell : pv \equiv v \pmod{\mathbf{Z}^2}\}$, and let $\mathcal{N}_{\ell,p}$ denote the Γ -module of divisors on the Γ -set $C_0(\mathbf{X}) \times \mathcal{V}_{\ell,p}$:

$$\mathcal{N}_{\ell,p} := \mathbf{Z}[C_0(\mathbf{X}) \times \mathcal{V}_{\ell,p}].$$

To be consistent with our previous notation, we denote the element corresponding to the pair (f, v) by $\varphi_{f,v}$. Let $H_1(\Gamma_0(\ell), \mathcal{N}_{\ell,p})_{\text{int}}$ denote the subgroup of $H_1(\Gamma_0(\ell), \mathcal{N}_{\ell,p})$ generated by cycles of the form $([A_1] - [A_2]) \otimes \varphi_{f,v}$, i.e. such simple tensors such that $A_1^t f = A_2^t f$ and $A_1^{-1}v = A_2^{-1}v$.

The pairing (4.122) then induces a pairing:

$$\begin{aligned} H^1(\Gamma_0(\ell), \mathcal{M}_{\ell,p})_{\text{int}} \times H_1(\Gamma_0(\ell), \mathcal{N}_{\ell,p})_{\text{int}} &\longrightarrow \mathcal{O}_p^\times \\ ([\mu], ([A_1] - [A_2]) \otimes \varphi_{f,v}) &\longmapsto \int_{\mathbf{X}} f(x) d\mu(A_1, A_2)(v)(x). \end{aligned} \tag{4.123}$$

Given the setting of our real quadratic field F , it is easy to check that if

$$f(x_1, x_2) := x_1 w_1 + x_2 w_2,$$

the cycle

$$\mathcal{C}_{f,v} := ([1] - [\gamma]) \otimes \varphi_{f,v}$$

defines a class $[\mathcal{C}_{f,v}] \in H_1(\Gamma_0(\ell), \mathcal{N}_{\ell,p})_{\text{int}}$. The main part of this verification is the observation that $\gamma^t f = \varepsilon \cdot f$, so the functions $\gamma^t f$ and f are equal in $C_0(\mathbf{X})$. We then have the following restatement of Conjecture 4.31:

Conjecture 4.32 (Multiplicative pairing form). *The element*

$$u_T(\mathbf{a}) := p^{\zeta_{K/F, R, T}(\sigma_{\mathbf{a}}, 0)} \langle [\mu_\ell], [\mathcal{C}_{f,v}] \rangle \in F_p^\times$$

is an element of $K \subset K_{\mathfrak{p}} \cong F_p$. Furthermore, $u_T(\mathbf{a}) \in U_{p, S, T}(K)$, and we have the ‘‘Shimura Reciprocity Law:’’

$$u_T(\mathbf{a})^{\sigma_{\mathbf{b}}} = u_T(\mathbf{a}\mathbf{b}).$$

4.5 General degree

The constructions of this chapter, from Sczech’s definition of the cocycle Ψ in Section 4.2 onward, generalize to degree $n \geq 2$. Furthermore, in the description above we removed $\{0\}$ from $(\mathbf{Q}/\mathbf{Z})^2$ in the definition of \mathcal{V} to simplify matters. In this section we describe the generalization to $n \geq 2$ and $\mathcal{V} := (\mathbf{Q}/\mathbf{Z})^n$.

4.5.1 Szech's construction of Ψ

Let $\Gamma = \mathbf{SL}_n(\mathbf{Z})$. For $i = 1, \dots, m$, let Q_i denote a linear form in n -variables with coefficients in \mathbf{R} that are linearly independent over \mathbf{Q} (in particular, all the coefficients are non-zero). Let $Q = \prod_{i=1}^m Q_i$, and let \mathcal{Q} denote the Γ -module of such products Q , with $\gamma Q(x) := Q(x\gamma)$. In our discussion above, we considered the case $m = n = 2$.

For an n -tuple of matrices $A = (A_1, \dots, A_n)$ and an element $z \in \mathbf{Z}^n$, let $\sigma = \sigma(A, z)$ denote the $n \times n$ matrix whose i th column σ_i is the first column of the matrix A_i that is not orthogonal to z . For a polynomial $P \in \mathcal{P} := \mathbf{Q}[x_1, \dots, x_n]$, let

$$\psi(A)(P, z) := P(-\partial_{z_1}, \dots, -\partial_{z_n}) \frac{\det(\sigma)}{\langle z, \sigma_1 \rangle \cdots \langle z, \sigma_n \rangle}.$$

If P is homogenous of degree d and $v \in \mathcal{V} = (\mathbf{Q}/\mathbf{Z})^n$, define

$$\Psi(A)(P, Q, v) := \frac{1}{(2\pi i)^{n+d}} \lim_{t \rightarrow \infty} \sum'_{\substack{z \in \mathbf{Z}^n \\ |\langle z, v \rangle| < t}} \psi(A)(P, z) \cdot e(\langle z, v \rangle).$$

Szech proved that this limit exists, but its value in general depends on Q (we saw this already in the proof of Theorem 4.7 when $n = 2$ and $v = 0$). Furthermore, its value is expressible in finite terms as a \mathbf{Q} -linear combination of generalized Dedekind sums. The dependence on Q is mild—only the signs of the coefficients of $Q_i(x\sigma^{-1})$ enter into the formula.

Next, we let \mathcal{M} denote the Γ -module of functions $\mathcal{P} \times \mathcal{Q} \times \mathcal{V} \rightarrow \mathbf{Q}$ that are distributions in the \mathcal{V} variable and linear in the \mathcal{P} variable, with

$$(\gamma f)(P, Q, v) := f(\gamma^t P, \gamma^{-1} Q, \gamma^{-1} v).$$

Then Ψ is a homogeneous $(n - 1)$ -cocycle for Γ on \mathcal{M} :

$$\Psi \in Z^{n-1}(\Gamma, \mathcal{M}).$$

Specializations of $[\Psi]$ yield the classical partial zeta-values of totally real fields F of degree n at nonpositive integers. Let $\mathfrak{a}, \mathfrak{f}$ denote integral ideals of F that are relatively prime. Let $\{w_1, \dots, w_n\}$ denote a \mathbf{Z} -basis of $\mathfrak{a}^{-1}\mathfrak{f}$, and define $v \in \mathbf{Q}^n$ by $1 = \sum_i v_i w_i$. Define $P \in \mathcal{P}$ and $Q \in \mathcal{Q}$ by

$$P(x) = \text{Norm}_{F/\mathbf{Q}} \left(\sum_{i=1}^n x_i w_i \right), \quad Q(x) = \text{Norm}_{F/\mathbf{Q}} \left(\sum_{i=1}^n x_i w_i^* \right),$$

where $\{w_i^*\}$ is the dual basis to $\{w_i\}$ with respect to the trace. Let $\{\varepsilon_i\}_{i=1}^{n-1}$ denote a basis for the (free abelian) group of totally positive units of \mathcal{O}_F^\times congruent to 1 (mod \mathfrak{f}). There is a sign condition on the regulator of the $\{\varepsilon_i\}$ to ensure compatibility with the orientation of the $\{w_i\}$, as in (4.13) and (4.15). Let $A_i \in \Gamma$ denote the matrix for multiplication by ε_i with respect to the basis $\{w_j\}$ considered as a row vector. Finally, let

$$A = \sum_{\pi \in S_{n-1}} \text{sgn}(\pi) [(1, A_{\pi(1)}, A_{\pi(1)} A_{\pi(2)}, \dots, A_{\pi(1)} A_{\pi(2)} \cdots A_{\pi(n-1)})] \in \mathbf{Z}[\Gamma^n].$$

Let K be the narrow ray class extension of F associated to the conductor \mathfrak{f} , and let R denote the set of infinite primes of F and the primes dividing \mathfrak{f} . Sczech proves

$$\zeta_{K/F,R}(\sigma_{\mathfrak{a}}, 1 - r) = \Psi(A)(P^{r-1}, Q, v) \in \mathbf{Q}$$

for each positive integer r .

4.5.2 ℓ -smoothing

The integrality results obtained from ℓ -smoothing Sczech's cocycle Ψ and applications towards the construction of p -adic zeta functions and Stark units is the topic of the work in progress [5]. The basic results are sketched here.

Let $\Gamma_0(\ell) \subset \Gamma$ denote the congruence subgroup containing those matrices whose first columns have every entry but the first divisible by ℓ . Let π_ℓ denote the $n \times n$ diagonal matrix whose first entry is ℓ and other diagonal entries are 1. For P homogeneous of degree d , define

$$\Psi_\ell(A)(P, Q, v) = \ell^d (\Psi(\pi_\ell A \pi_\ell^{-1}, \pi_\ell^{-1} P, \pi_\ell Q, \pi_\ell v) - \ell \Psi(A, P, Q, v)).$$

The smoothed cocycle Ψ_ℓ satisfies the following integrality property analogous to Theorem 4.15:

$$\Psi_\ell(A)(P, Q, v) \in \frac{1}{m2^n} \mathbf{Z}[\frac{1}{\ell}]$$

if $P \in \mathbf{Z}[\frac{1}{\ell}][x_1, \dots, x_n]$ and v satisfy

$$P(v + \frac{1}{\ell} \mathbf{Z} \oplus \mathbf{Z}) \subset \mathbf{Z}[\frac{1}{\ell}].$$

Up to the factor $m2^n$, which we are currently trying to eliminate using arguments such as those in Lemmas 4.22 and 4.23, this integrality property implies Theorem 4.6 of Deligne–Ribet, Cassou–Nogues, and Barsky for the partial zeta functions of F :

$$\zeta_{K/F,R,T}(\sigma_{\mathfrak{a}}, 1 - r) \in \mathbf{Z}[\frac{1}{\ell}]$$

for positive integers r , where $T = \{\mathfrak{c}\}$ for a prime of F of norm ℓ .

The arguments of Section 4.4.3 can be generalized to define a cocycle of measures μ on the sets $\mathbf{Y}_v = v + \mathbf{Z}_p^n$. The cocycle μ can in turn be used to produce the p -adic partial zeta functions of F as in (4.110):

$$\zeta_{K/F,S,T,p}(\sigma_{\mathfrak{a}}, s) := \int_{\mathbf{Y}_v} P(x)^{-s} d\mu(A)(Q, v)(x),$$

where S contains all primes of F above p . Finally, we may state a conjectural formula for Stark units in the general case TR_p as in (4.30). For simplicity we assume that p is inert in F and that $p \equiv 1 \pmod{\mathfrak{f}}$. We only present the logarithmic form of the conjecture because of the nuisance factor $n2^n$ (note $m = n$ for our choice of Q) that prevents the definition of \mathbf{Z} -valued measures.

Conjecture 4.33. *Let $f(x) = x_1 w_1 + \dots + x_n w_n$. We have*

$$\log_p(u_T^{\sigma_{\mathfrak{a}}}) = \int_{\mathbf{X}} \log_p(f(x)) d\mu_\ell(A)(Q, v)(x) \in \mathcal{O}_{F,p}.$$

Bibliography

- [1] T. Arakawa, *Generalized eta-functions and certain ray class invariants of real quadratic fields*. Math. Ann. 260 (1982), 475–494.
- [2] D. Barsky. *Fonctions zeta p -adic d’une classe de rayon de nombres totalement réels*. Groupe d’Etude d’Analyse Ultramétrique (5e année: 1977/78), Exp. No. 16, 23 pp., Secrétariat Math., Paris, 1978.
- [3] Pi. Cassou–Noguès. *Valuers aux entiers négatifs des fonctions zêta et fonctions zêta p -adique*. Invent. Math. **51** (1979), no. 1, 29–59.
- [4] P. Charollois, H. Darmon. *Arguments des unités de Stark et périodes de séries d’Eisenstein*. (French) [Arguments for the Stark units and periods of Eisenstein series] Algebra Number Theory 2 (2008), no. 6, 655–688.
- [5] P. Charollois, S. Dasgupta. *An Integral Eisenstein Cocycle and Gross–Stark Units for Totally Real Fields*. In preparation.
- [6] P. Colmez. *Résidu en $s = 1$ des fonctions zêta p -adic*, Invent. Math. **91** (1988), no. 2, 371–389.
- [7] J. Coates, W. Sinnott. *On p -adic L -functions over Real Quadratic Fields*. Invent. Math. **25** (1974), 253–279.
- [8] H. Darmon, S. Dasgupta. *Elliptic Units for Real Quadratic Fields*. Ann. of Math. (2) 163 (2006), no. 1, 301–346.
- [9] H. Darmon, S. Dasgupta, R. Pollack *Hilbert modular forms and the Gross–Stark conjecture*. Ann. of Math. in press.
- [10] S. Dasgupta. *Computations of Elliptic Units for Real Quadratic Fields*. Canad. J. Math. 59 (2007), no. 3, 553–574.
- [11] S. Dasgupta. *Shintani Zeta Functions and Gross–Stark Units for Totally Real Fields*. Duke Math. J. **143** (2008), no. 2, 225–279.
- [12] P. Deligne, K. Ribet. *Values of abelian L -functions at negative integers over totally real fields*. Invent. Math. **59** (1980), no. 3, 227–286.

- [13] D. Dummit, J. Sands, B. Tangedal, *Computing Stark units for totally real cubic fields*. Math. Comp. **66** (1997), no. 219, 1239–1267.
- [14] D. Dummit, B. Tangedal, P. van Wamelen, *Stark’s conjecture over complex cubic number fields*. Math. Comp. **73** (2004), no. 247, 1525–1546
- [15] B. Gross, *p -adic L -series at $s = 0$* . J. Fac. Sci. Univ. Tokyo Sect. IA Math. **28** (1981), no. 3, 979–994 (1982).
- [16] B. Gross, *On the values of abelian L -functions at $s = 0$* . J. Fac. Sci. Univ. Tokyo Sect. IA Math. **35** (1988), no. 1, 177–197.
- [17] R. Hill, *Shintani cocycles on \mathbf{GL}_n* . Bull. Lond. Math. Soc. **39** (2007), no. 6, 993–1004.
- [18] S. Hu, D. Solomon. *Properties of higher-dimensional Shintani generating functions and cocycles on $\mathbf{PGL}_3(\mathbf{Q})$* . Proc. London Math. Soc. (3) **82** (2001), no. 1, 64–88.
- [19] B. Mazur. *On the Arithmetic of Special Values of L -functions*. Invent. Math. **55** (1979), 207–240.
- [20] T. Ren, R. Sczech, *A refinement of Stark’s conjecture over complex cubic number fields*. J. Number Theory **129** (2009), no. 4, 831–857.
- [21] J. Sands. *Galois groups of exponent two and the Brumer–Stark conjecture*. J. Reine Angew. Math. **349** (1984) 129–135.
- [22] R. Sczech. *Zur Summation von L -Reihen*. (German) [On the summation of L -series] Dissertation, Rheinische Friedrich-Wilhelms-Universität, Bonn, 1981. Bonner Mathematische Schriften [Bonn Mathematical Publications], 141.
- [23] R. Sczech. *Eisenstein cocycles for $\mathbf{GL}_2(\mathbf{Q})$ and values of L -functions in real quadratic fields*. Comment. Math. Helv. **67** (1992), no. 3, 363–382.
- [24] R. Sczech. *Eisenstein Group Cocycles for \mathbf{GL}_n and values of L -functions*. Invent. Math. **113** (1993), no. 3, 581–616.
- [25] J. P. Serre. *A Course in Arithmetic*. Graduate Texts in Mathematics, No. 7. New York–Heidelberg, 1973.
- [26] T. Shintani, *On evaluation of zeta functions of totally real algebraic number fields at non-positive integers*. J. Fac. Sci. Univ. Tokyo Sect. IA Math. **23** (1976), no. 2, 393–417.
- [27] T. Shintani, *On certain ray class invariants of real quadratic fields*, Proc. Japan Acad. **53** (1977), 128–131.
- [28] T. Shintani, *A proof of the classical Kronecker limit formula*. Tokyo J. Math. **3** (1980), 191–199.

- [29] C. Siegel. *Bernoullische Polynome und quadratische Zahlkörper*. Nachr. Akad. Wiss. Göttingen Math.–Phys. Kl. II (1968), 7–38.
- [30] D. Solomon, *Algebraic properties of Shintani’s generating functions: Dedekind sums and cocycles on $\mathbf{PGL}_2(\mathbf{Q})$* . Compositio Math. 112 (1998), no. 3, 333–362.
- [31] D. Solomon, *The Shintani cocycle. II. Partial zeta functions, cohomologous cocycles and p -adic interpolation*. J. Number Theory 75 (1999), no. 1, 53–108.
- [32] H. Stark, *L -functions at $s = 1$. IV. First derivatives at $s = 0$* . Adv. in Math. **35** (1980) , no. 3, 197–235.
- [33] J. Tate. *On Stark’s conjectures on the Behaviour of $L(s, \chi)$ at $s = 0$* . J. Fac. Sci. Univ. Tokyo Sect. 1A Math. **28** (1981), no. 3, 963–978.
- [34] A. Weil. *Elliptic Functions According to Eisenstein and Kronecker*. Springer–Verlag, Berlin, 1976.
- [35] S. Yamamoto. *On Shintani’s ray class invariant for totally real number fields*, Math. Ann. 364 (2010), 449–476.